

REMOVABLE COVER, MAY BE VENTED OR UNVENTED DEPENDING ON APPLICATION REQUIREMENTS. CONSULT FACTORY FOR APPLICATION REQUIREMENTS

NOTES:

****IMPROPER VENTING WILL HAVE A NEGATIVE EFFECT ON PERFORMANCE****

STINGER SCREW FEEDER

STANDARD MATERIALS OF CONSTRUCTION ARE: 304 S/S HOUSING WITH 316 S/S FLUIDIZING MEDIA, 303 S/S AUGER, UHMW SHAFT SEAL, ZINC PLATED C/S HARDWARE

AUGER

- AVAILABLE MATERIALS OF CONSTRUCTIONS
- POLYETHYLENE FLIGHTING WITH STAINLESS STEEL HEX SHAFT
 - MACHINED PLASTICS (MATERIAL OF CONSTRUCTION IS APPLICATION DEPENDANT)
 - FABRICATED OR MACHINED CARBON STEEL
 - FABRICATED OR MACHINED 303 STAINLESS STEEL
 - FABRICATED OR MACHINED 316 STAINLESS STEEL

FEED HOPPER

- MATERIAL OF CONSTRUCTION EITHER PAINTED CARBON STEEL, 304 S/S OR 316 S/S

SUPPORT FRAME

- WELDED STEEL CONSTRUCTION
- AVAILABLE IN EITHER PAINTED CARBON STEEL OR STAINLESS STEEL

WEIGH SCALE

- REQUIRED FOR GRAVIMETRIC RATE OR BATCH APPLICATIONS
- CONSISTS OF (3) METTLER TOLEDO WEIGH MODULES
- LOAD CELLS MAY BE EITHER
 - DIGITAL TO MEET HIGH ACCURACY REQUIREMENTS
 - ANALOG WHEN HIGH ACCURACY IS NOT REQUIRED

NOTE: ULTRA-PRECISION SCALES ARE AVAILABLE TO MEET THE MOST DEMANDING APPLICATION REQUIREMENTS. CONTACT YOUNG INDUSTRIES FOR MORE INFO.

DRIVE ASSY

- MOTOR:

- STANDARD VOLTAGE: MARATHON BLACK-MAX, TENV, 3PH/230V/460V/60HZ

- OPTIONS INCLUDE:

- EXPLOSION PROOF MOTOR
- TEFC
- CUSTOM MOTOR PER CUSTOMER SPECS

- REDUCER:

- STANDARD: NORD 'SK' SERIES HELICAL BEVEL DESIGN WITH CAST ALUMINUM HOUSING, NEMA MOTOR MOUNT, AND KEYLESS, SHRINK SHAFT FOR EASY AUGER REMOVAL. REDUCER SIZED FOR 24/7 OPERATION AT 60 HZ OR MOMENTARY BATCH APPLICATIONS WITH MAX SPEED RANGE UP TO 120HZ

CONTROLS

SEE YOUNG INDUSTRIES CONTROLS BULLETINS FOR AVAILABLE OPTIONS

CUSTOM ORDERS

CUSTOM DESIGNS WITH FEATURES AND DIMENSION OTHER THAN THOSE SPECIFIED ARE AVAILABLE. CONTACT YOUNG INDUSTRIES OR YOUR LOCAL YOUNG INDUSTRIES REPRESENTATIVE FOR MORE INFORMATION

* THIS DRAWING SHOULD BE USED FOR REFERENCE ONLY AND SHOULD NOT BE USED FOR BUILDING PURPOSES. ALL DETAILS ARE SUBJECT TO CHANGE WITHOUT NOTICE.

****LIFTING NOTE****

WHEN LIFTING UNIT FROM HOPPER LUGS, "SAFELOCK" LOAD CELL BLOCKING PLATES MUST BE INSTALLED OR PERMANENT SCALE DAMAGE WILL OCCUR. PLATES ARE USED TO LOCK LOAD CELL IN PLACE DURING SHIPPING, INSTALLATION OR WHILE MOVING UNIT.

****LENGTH NOTE****

FEED TUBE LENGTH RANGE LISTED IS BASED ON PERFORMANCE. IF LENGTH IS EXTENDED BEYOND RANGE, THERE MAY BE AN EFFECT ON PERFORMANCE. CONTACT YOUNG INDUSTRIES FOR MORE INFO IF YOUR APPLICATION REQUIRES AN EXTENDED LENGTH

HOPPER DIA. (AH)	HOLDING CAPACITY (CU. FT.)	BH	CH	DH	EH	FH	GH	HH
36"	10	19.75	43.91	8.00	4.00	29.00	51.31	45.50
	18	32.75	56.91					
	23	40.25	64.41					
48"	20	22.25	54.83	8.00	4.00	35.00	61.69	54.50
	30	30.75	65.33					
	40	39.75	74.33					

FEEDER SIZE (AF)	CAPACITY (CU. FT./HR) @ 100% FILL	BF STANDARD	BF AVAIL. RANGE (GRAVIMETRIC)	BF AVAIL. RANGE (VOLUMETRIC)	CF	DF	EF	EFA	FF	GF
1.00	.08 - 4.0	18.00	12.00 - 32.00	12.00 - 32.00	4.00	4.00	5.00	9.50	4.81	13.00
1.50	0.7 - 15	18.00	24.00 - 60.00	24.00 - 60.00	4.00	4.00	5.00		4.81	13.00
2.00	1.6 - 35	18.00	24.00 - 60.00	24.00 - 60.00	4.00	4.00	5.00		4.81	13.00
3.00	5.7 - 120	36.00	24.00 - 60.00	24.00 - 72.00	5.50	6.00	5.00	10.75	5.56	13.00
4.00	14 - 290	36.00	24.00 - 60.00	24.00 - 72.00	5.50	6.00	5.00		5.56	13.00
5.00	27 - 550	36.00	24.00 - 60.00	24.00 - 96.00	7.00	8.00	8.00		7.31	16.00
6.00	34 - 700	48.00	24.00 - 60.00	24.00 - 96.00	7.00	8.00	8.00	13.0	7.31	16.00
8.00	70 - 1,450	48.00	24.00 - 60.00	24.00 - 120.00	8.75	10.00	8.50		13.88	8.31

NOTES:

1. "BF STANDARD" IS DEFAULT LG. FOR LIW APPLICATIONS AND WILL RESULT IN OPTIMUM PERFORMANCE WITH CG AT OR NEAR CL.
2. "BF AVAIL. RANGE" IS FOR EXTENDED LENGTH AND CUSTOM APPLICATIONS.
3. "VOLUMETRIC" APPLICATIONS ARE THOSE WHO DO NOT HAVE A SCALE ON THE FEEDER UNIT. MAY ALSO BE APPLIED TO GIW APPLICATIONS WITH SCALE EXTERNAL TO FEEDER

(3) METTLER TOLEDO LOAD CELLS, MAY BE ANALOG OR DIGITAL TO MEET APPLICATION REQUIREMENTS.

SCALE SHIPS WITH SECURITY PLATES INSTALLED TO LOCK SCALE IN SAFE POSITION FOR TRANSPORT AND INSTALLATION

HEAVY DUTY SUPPORT FRAME, CONSTRUCTED FROM 4X4X.25" SQ. TUBING FOR STABLE AND ACCURATE WEIGHING

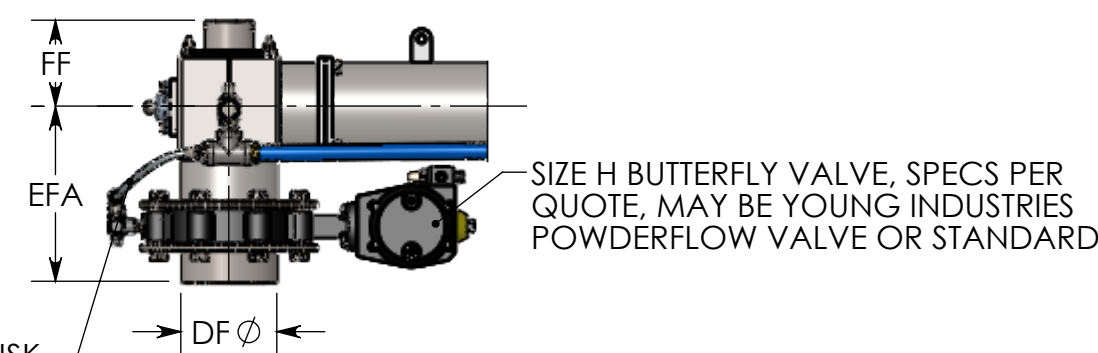
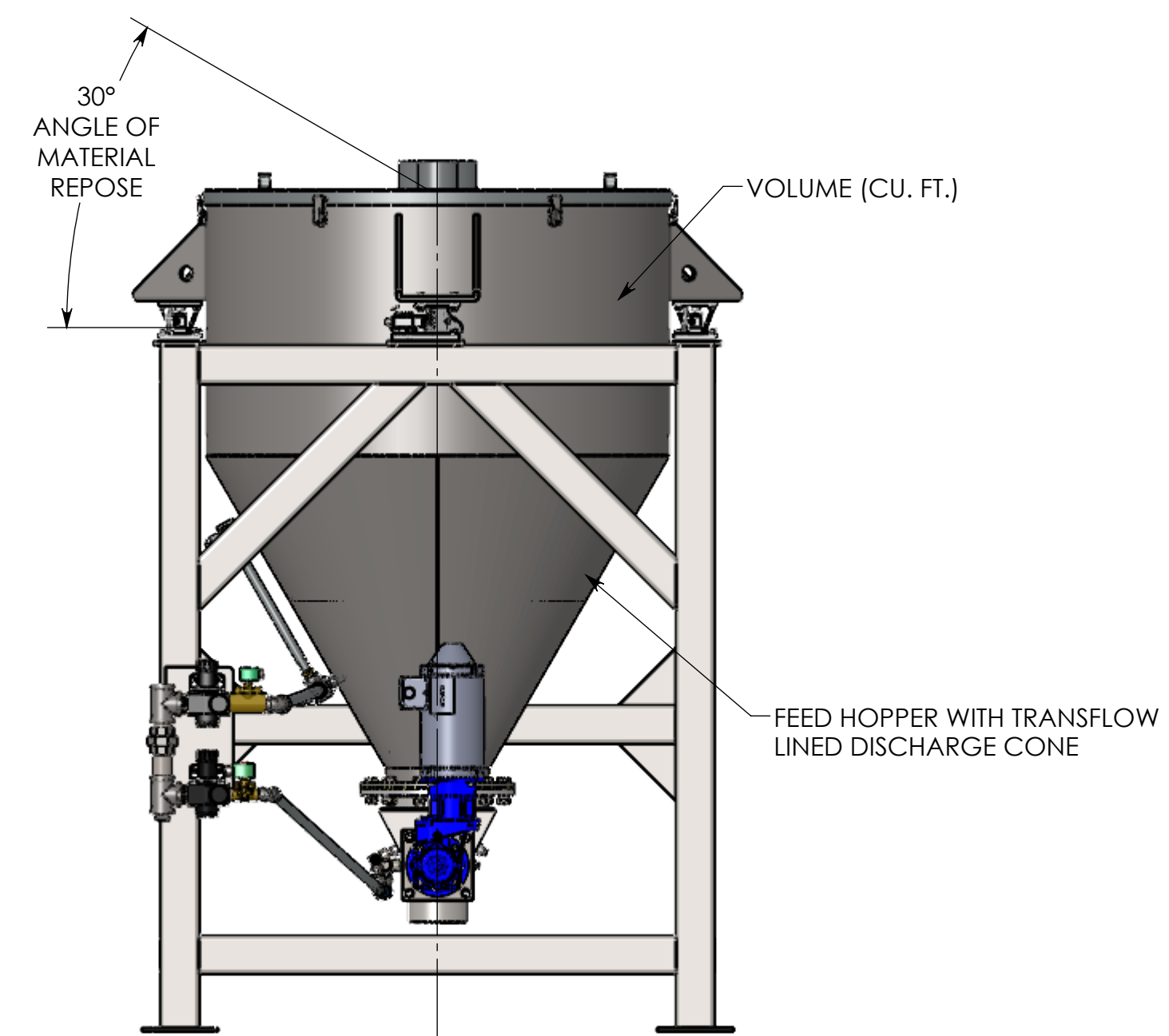
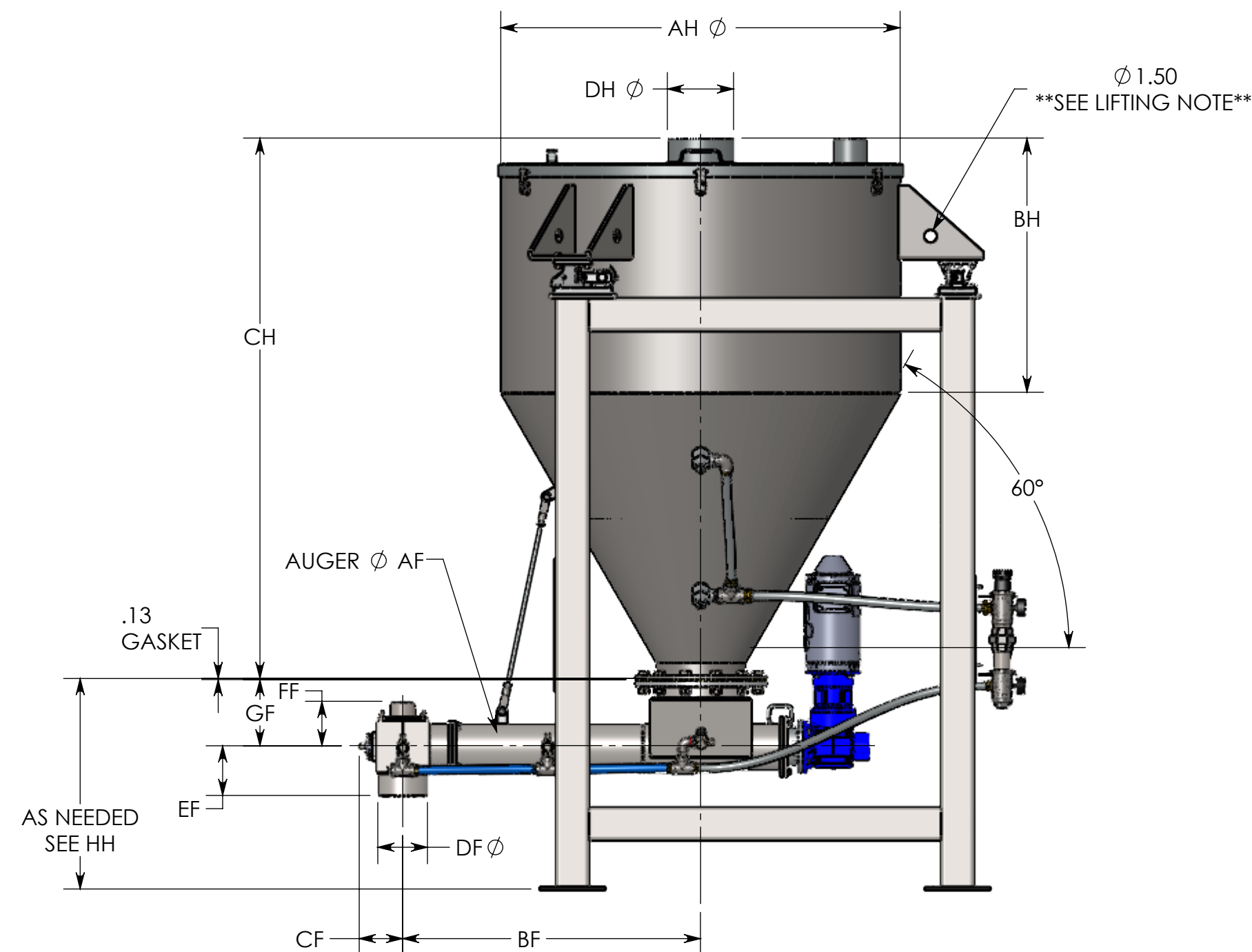
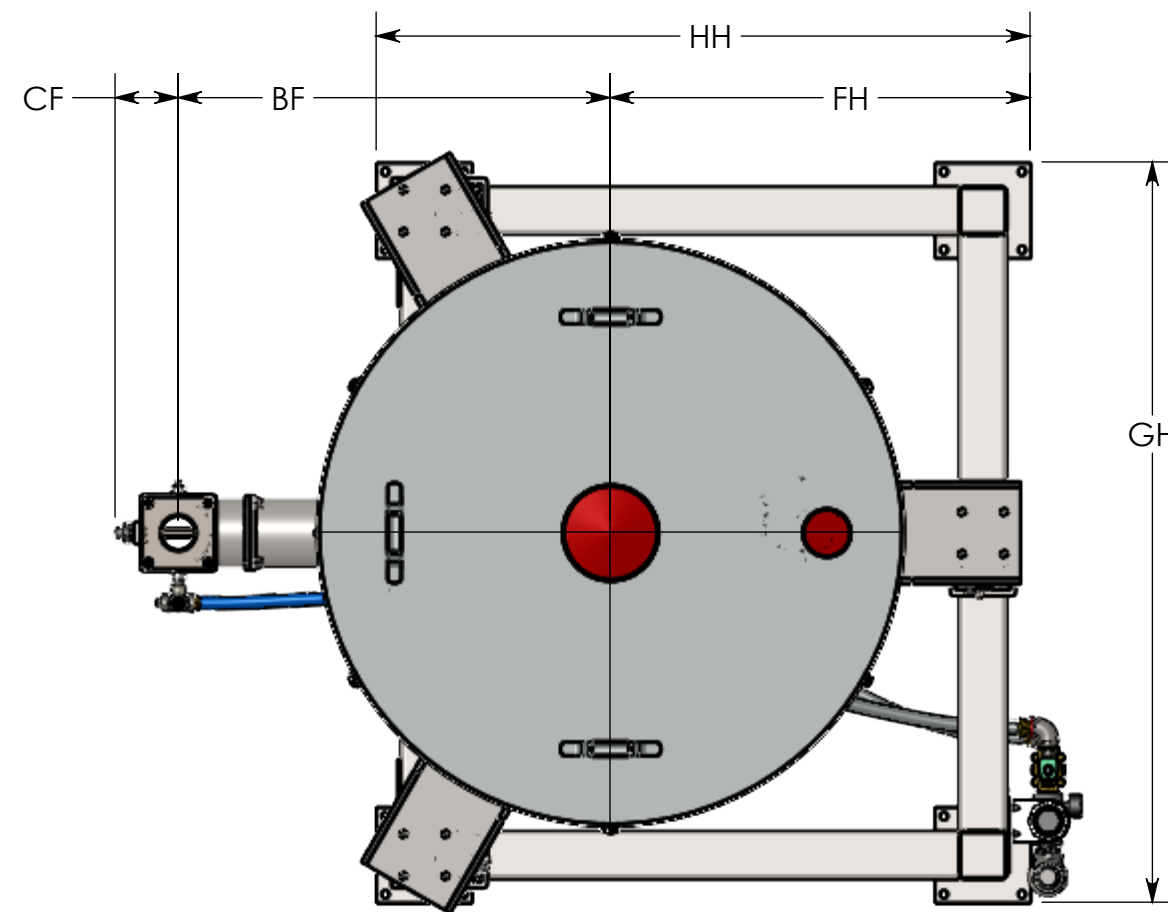

REF. AIR SUPPLY TO POWDERFLOW VALVE DISK (ONLY WHEN SPECIFIED)

DISCHARGE SHOWN WITH OPTIONAL FLANGED CONNECTION AND BUTTERFLY VALVE. SEE NOTES

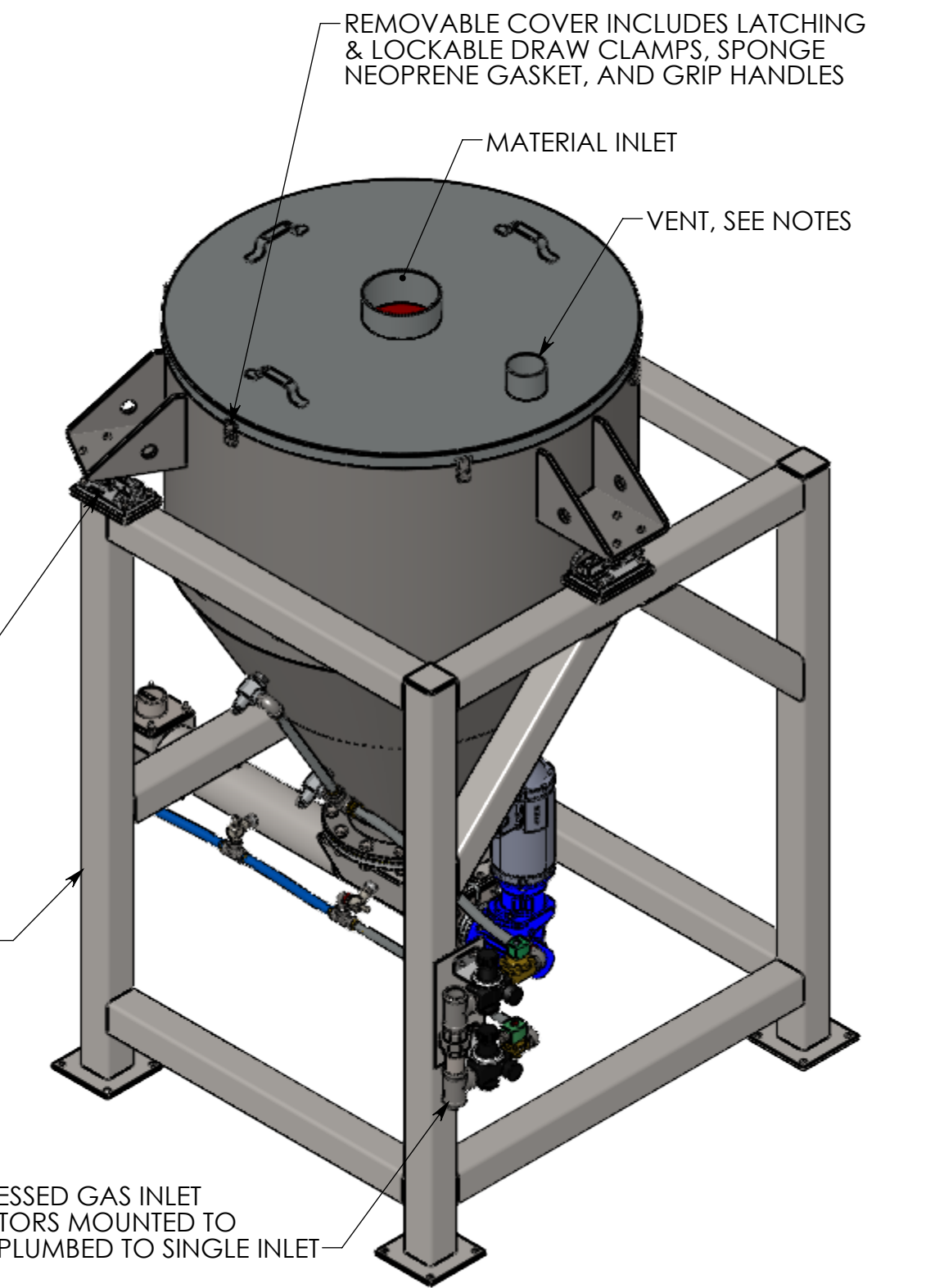

REMOVABLE COVER INCLUDES LATCHING & LOCKABLE DRAW CLAMPS, SPONGE NEOPRENE GASKET, AND GRIP HANDLES

MATERIAL INLET

VENT, SEE NOTES

HEAVY DUTY SUPPORT FRAME, CONSTRUCTED FROM 4X4X.25" SQ. TUBING FOR STABLE AND ACCURATE WEIGHING

COMPRESSED GAS INLET REGULATORS MOUNTED TO FRAME. PLUMBED TO SINGLE INLET

REV. NO.	DESCRIPTION	DATE	BY
3	UPDATED DESIGN TO MATCH CURRENT STANDARDS	12/16/19	JAH
2	REV DISCH. COVR, REPLACE FEED TUBE COUPLING WITH FLANGE CONNECTION	03/19/18	JAH
1	RAISED LOCATION OF SUPPRT. LUGS, UPDATED DIMENSIONS, CHANGED HOPPER ANGLE FROM 45DEG. TO 60 DEG.	04/14/16	JAH

REVISIONS			
CUSTOMER			
CUST. NO.			
YOUNG ORDER NO.			
TITLE			
ASSY: YOUNG INDUSTRIES FEEDER - MODEL STS-2 WITH 10 TO 40 CU. FT. HOPPER			

THE YOUNG INDUSTRIES, INC.
 HUNTSVILLE, PENNSYLVANIA 17756
 TELEPHONE: 370-546-3165

DRAWN BY: JAH DATE DRAWN: 04/13/16
 CHECKED BY: JAH SCALE: 1:12
 DRAWING NUMBER: D-20567-03 REV: 3

GENERAL TOLERANCES	
UNLESS OTHERWISE SPECIFIED THE FOLLOWING SHALL APPLY	
MACHINING - .XX= .02 .XXX= .005 ANGLE= .50°	
FABRICATION - UNDER 6 6 TO 24 24 TO 60 OVER 60	± .06 ± .12 ± .19 ± .25
UNLESS OTHERWISE SPECIFIED DIMENSIONS ARE IN INCHES	