

NOTES:

1. INSTALL BETWEEN STANDARD ANSI CLASS 125/150# FLANGES
2. GAS REQUIREMENT: 3 TO 11 SCFM AT 3 TO 15 PSIG
3. MANUAL OR PNEUMATIC ACTUATORS

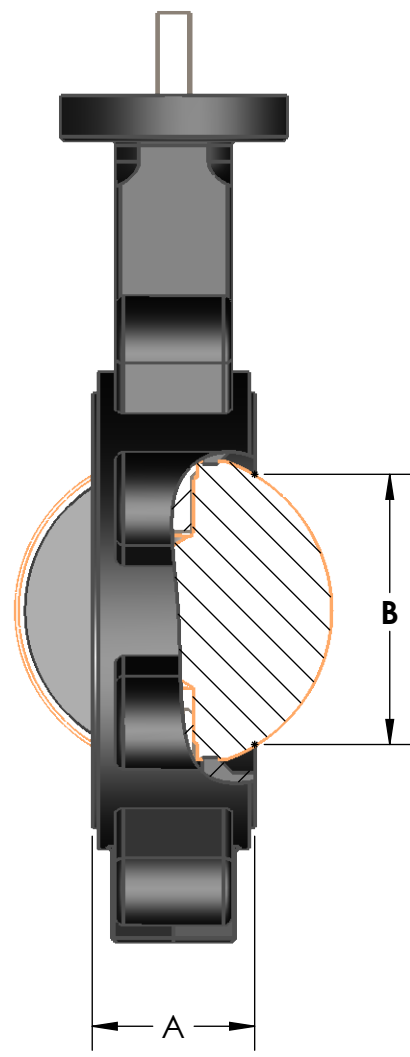
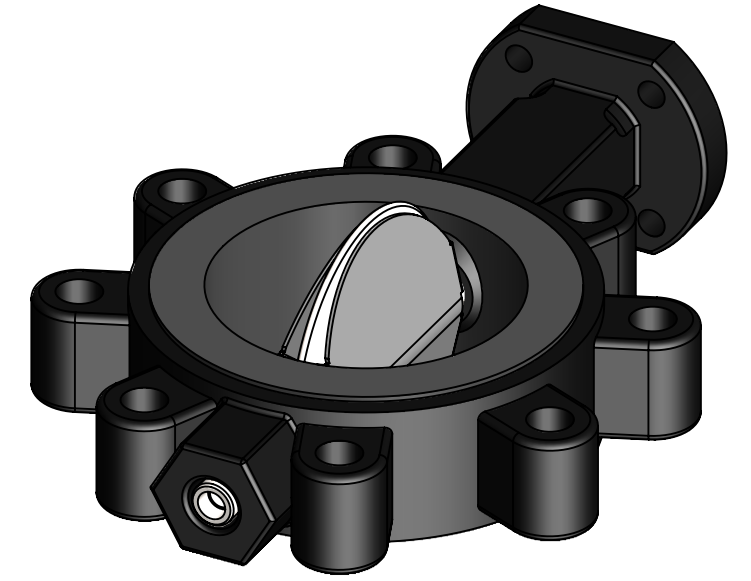

03	UPDATED NOTES, PLUMBING, AND DIMENSIONS	03/17/21	JAH
02	ADDED FLOW CONTROL VALVE AND TUBE FITTING	10/15/20	JAH
01	ADDED 2" VALVE SIZE, ADDED PIPE SIZE 'K'	07/31/18	JAH
REV. NO.	DESCRIPTION	DATE	BY

REVISIONS

CUSTOMER:

CUSTOMER PO NUMBER:

YOUNG JOB NUMBER:

TITLE

YOUNG INDUSTRIES LUG STYLE POWDER-FLOW BUTTERFLY VALVE STANDARD DIMENSION SHEET

REFERENCE PRODUCT LINE REPORT 018-234



DRAWN BY: BMF		DATE DRAWN: 01/05/18	
CHECKED BY:		SCALE = 1:2.5	
DRAWING NUMBER	B-20585-00	SHEET: 1 OF 1	REV: 03

PATENTED

VALVE SIZE	A	B	C	D	E	F	G	H	J	K	ISO
1.5	1.30	0.81	4.33	(4) 5/8-11 UNC	2.5	4.9	1.18	.354	1.97	1/16	F05
2	1.69	1.13	4.75		2.6	5.1					
2.5	1.81	1.79	5.50		3.2	5.6					
3	1.81	2.45	6.00		3.5	5.8					
4	2.05	3.50	7.50	(4) 3/4-10 UNC	4.3	6.7	.433	2.76	1/8	F07	
5	2.20	4.55	8.50		4.8	7.4					
6	2.20	5.71	9.50		5.4	8.0					
8	2.36	7.77	11.75		6.7	9.4					
10	2.68	9.76	14.25	(4) 7/8-9 UNC	7.9	10.7	.669	4.02	1/4	F10	
12	3.07	11.73	17.00		9.3	12.0					.866

DIMENSIONS ARE IN INCHES

GENERAL TOLERANCES
UNLESS OTHERWISE SPECIFIED THE FOLLOWING SHALL APPLY
MACHINING - .XX= .02 .XXX= .005 ANGLE= .50° SURFACE ROUGHNESS HEIGHT 63 MICROINCHES OR LESS
FABRICATION - UNDER 6 6 TO 24 24 TO 60 OVER 60 ± .06 ± .12 ± .19 ± .25
UNLESS OTHERWISE SPECIFIED DIMENSIONS ARE IN INCHES