

STANDARD CHARGE HOPPER DETAIL
1.50 CU. FT. CAPACITY
(OPTIONAL)

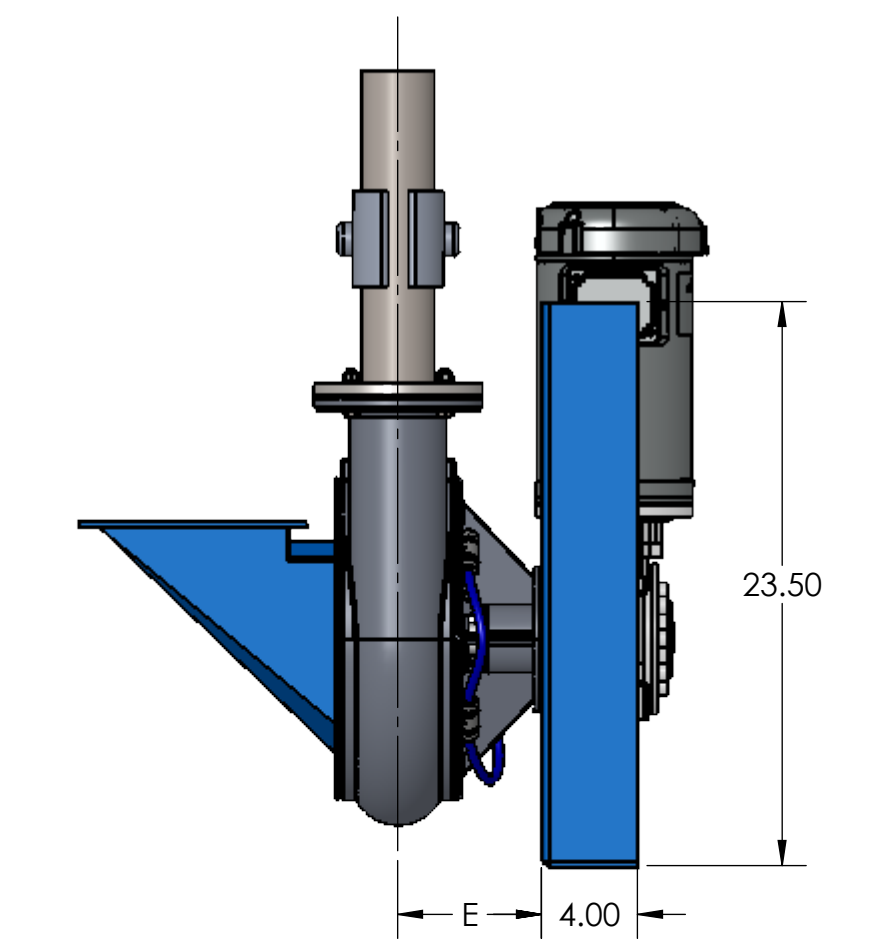
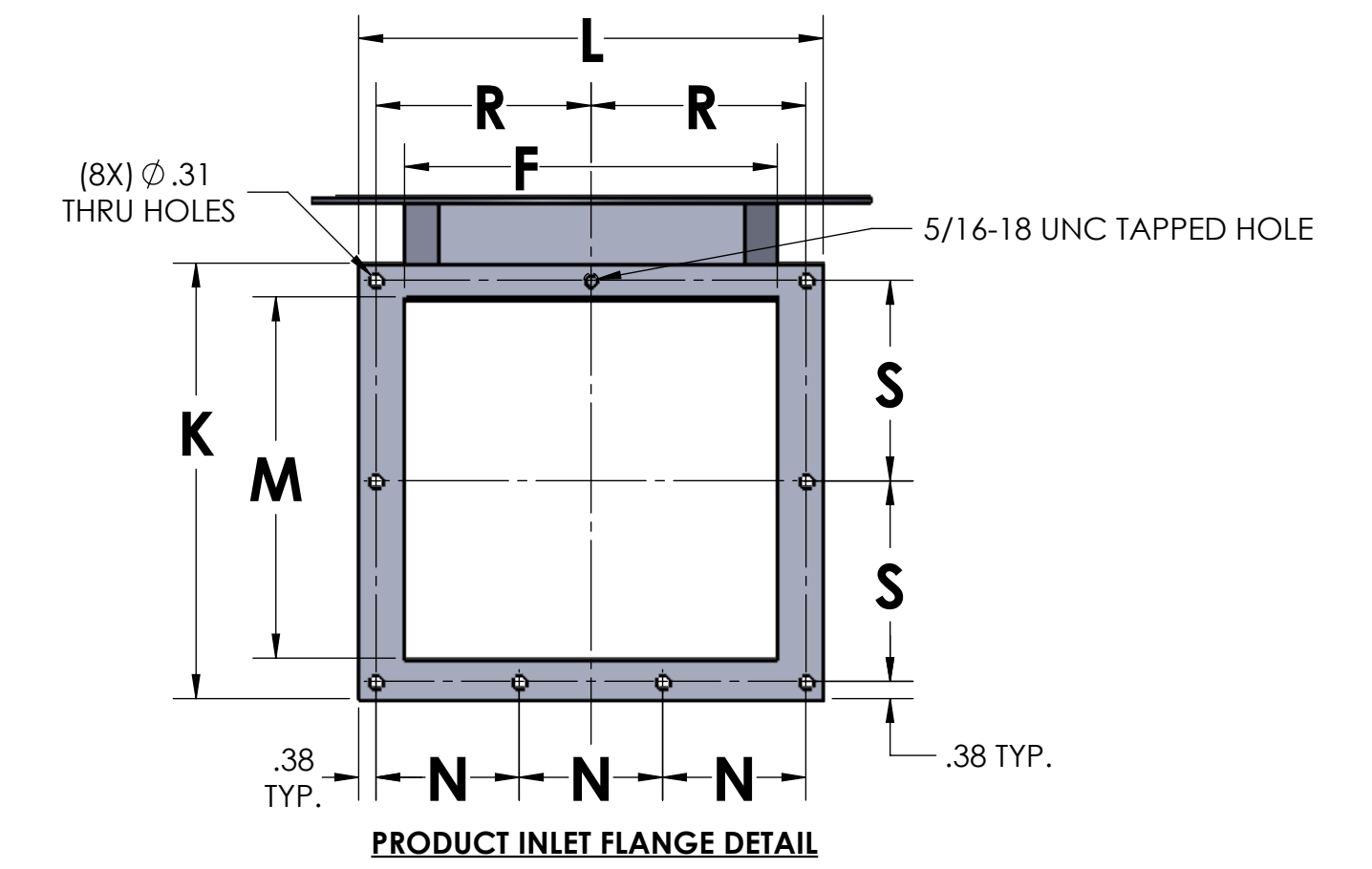

BOTTOM DRIVE DETAIL
(OPTIONAL)

THIS IS A PRELIMINARY SKETCH ONLY. DIMENSIONS ARE ESTIMATED. NOT FOR FABRICATION.

TUBE SIZE	A	B	C	D	E	F	G1 X G2	H	J	K	L	M	N	P	R	S	T
3"	11.50	9.50	11.50	14.38	6.00	7.88	24.00 X 20.00	18.44	8.56	9.50	10.25	7.75	3.13	30.00	4.69	4.38	6.44
4"	15.25	11.38	15.25	17.63	6.63	9.56	24.00 X 20.00	18.88	9.31	11.13	10.63	9.56	3.25	31.00	4.88	5.22	6.44

GENERAL TOLERANCES	
UNLESS OTHERWISE SPECIFIED THE FOLLOWING SHALL APPLY	
MACHINING - .XX= .02 .XXX= .005 ANGLE= .50°	
SURFACE ROUGHNESS HEIGHT 63 MICRONS OR LESS	
FABRICATION - UNDER 6 6 TO 24 24 TO 60 OVER 60	
± .06 ± .12 ± .19 ± .25	
UNLESS OTHERWISE SPECIFIED DIMENSIONS ARE IN INCHES	

01	ADDED DIMENSIONS, ADJUSTED CHARGE HOPPER DIMS	07/19/19	MRK
REV. NO.	DESCRIPTION	DATE	BY
REVISIONS			
CUSTOMER:			
CUSTOMER PO NUMBER:			
YOUNG JOB NUMBER:			
TITLE			
YOUNG INDUSTRIES TRANSAIR MECHANICAL CONVEYOR (TMC), MODEL 'VH' TOP DRIVE W/ SHAFT MOUNTED DRIVE, SIZE 3" & 4"			
THE YOUNG INDUSTRIES, INC. MUNCY, PENNSYLVANIA 17756 TELEPHONE: 570-546-3165			
DRAWN BY: SMR		DATE: 01/16/19	
CHECKED BY:		SCALE=1:1	
DRAWING NUMBER		SHEET	REV:
D-21118-10		1 OF 1	01