

- NOTES:
1. HORIZONTAL MIXER BODIES ARE AVAILABLE IN CARBON STEEL OR STAINLESS STEEL. OTHER MATERIALS MAY BE AVAILABLE UPON REQUEST. JACKETS MAY BE ADDED FOR HEATING AND COOLING OF PRODUCT.
  2. ONE (1) STANDARD DOUBLE RIBBON, MULTIPITCH OR PADDLE AGITATOR.
  3. GASKET MATERIAL: NEOPRENE, RTV, OR CUSTOMER SPECIFIED.
  4. MATERIAL FINISH:  
C/S PLATE/SHEET FINISH - HOT ROLLED  
S/S SHEET FINISH - NO. 2B  
S/S PLATE FINISH - H.R.A.P.
  5. DESIGN/OPERATING TEMPERATURE: AMBIENT
  6. PAINT SPECIFICATION: YOUNG INDUSTRIES STANDARD 082-500 Y.I. BLUE EPOXY OR CUSTOMER SPECIFIED PAINT. STAINLESS STEEL IS NOT PAINTED.
  7. SHORT AND LONG MIXER BODIES AVAILABLE

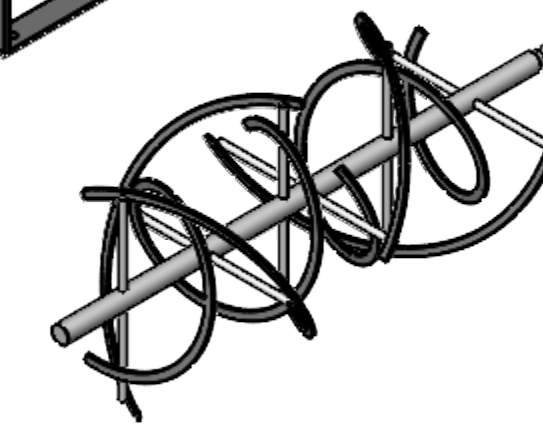

MULTI-PITCH AGITATOR

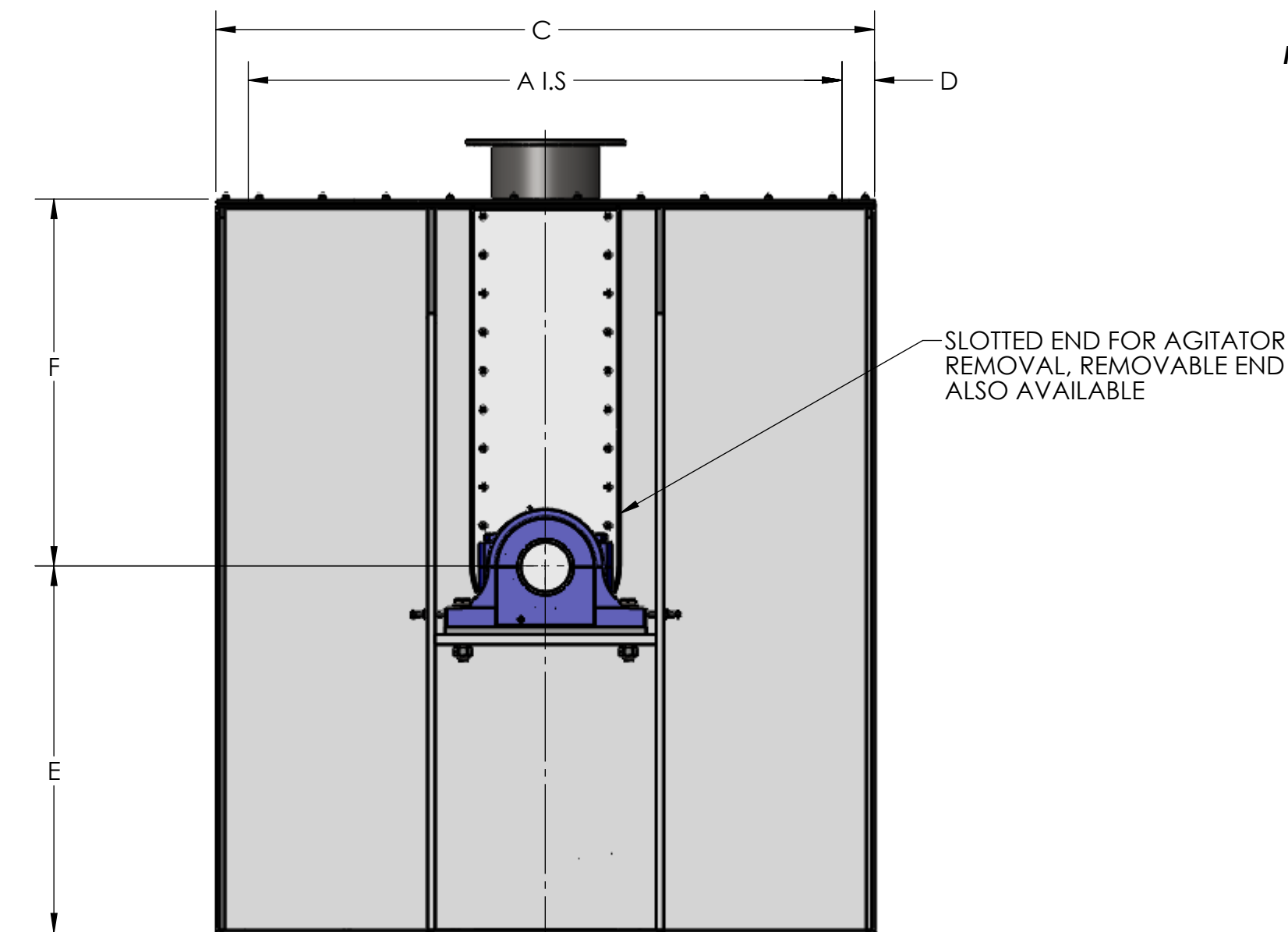
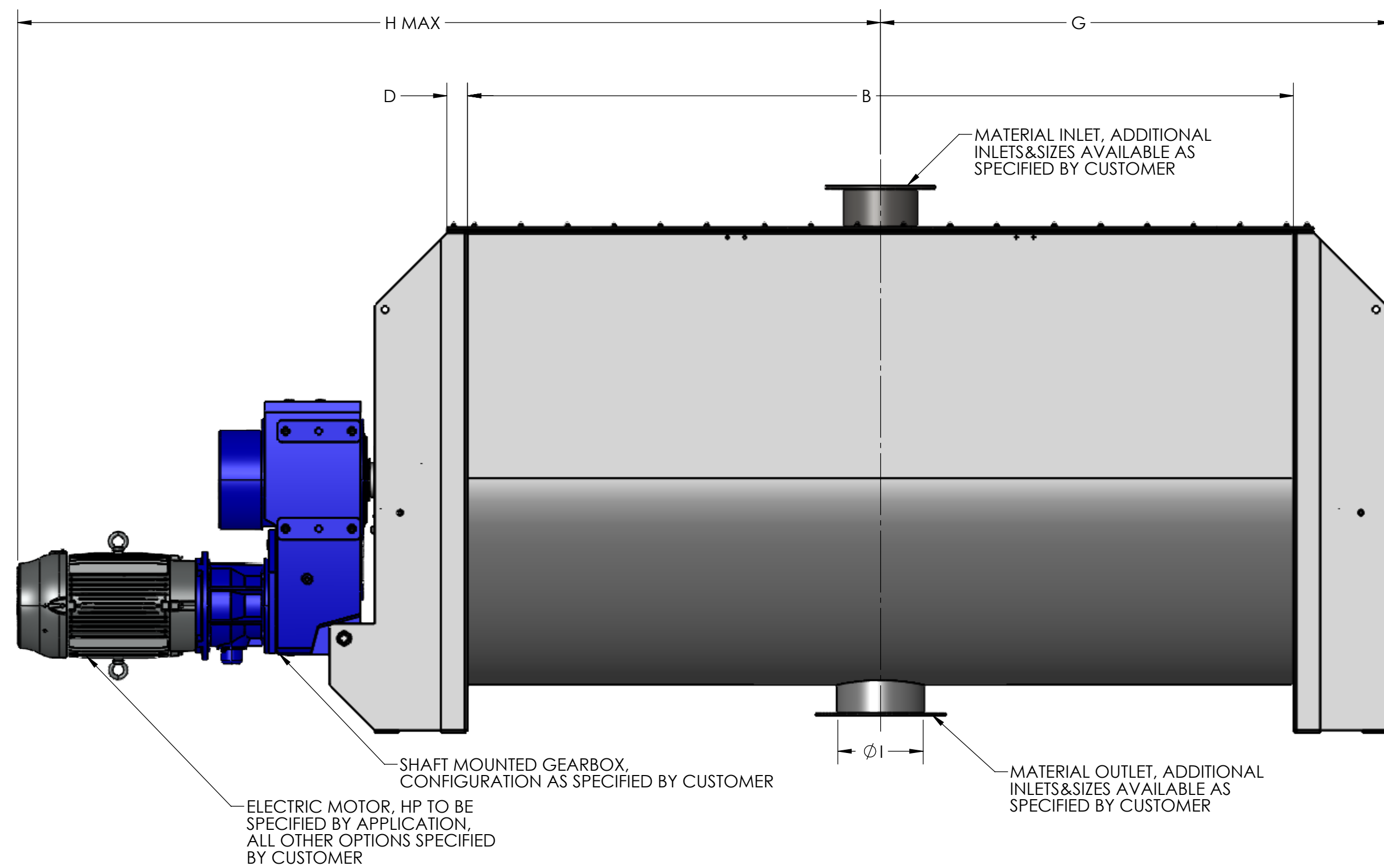
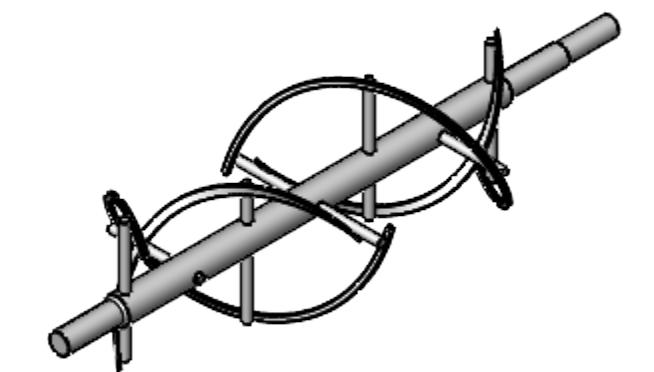

STANDARD DOUBLE RIBBON AGITATOR

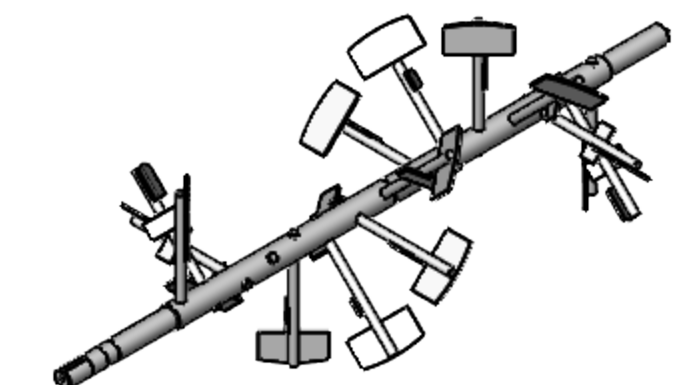

PADDLE AGITATOR

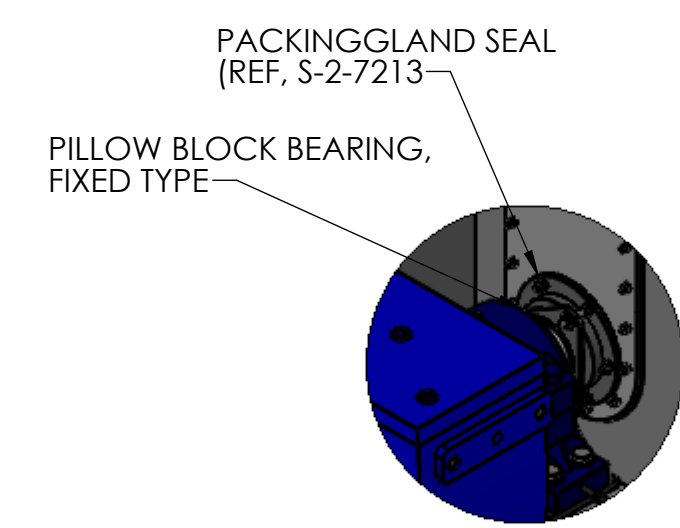

DRIVE SIDE DETAIL  
\*NOTE STIFFENER HIDDEN TO SHOW DETAIL\*

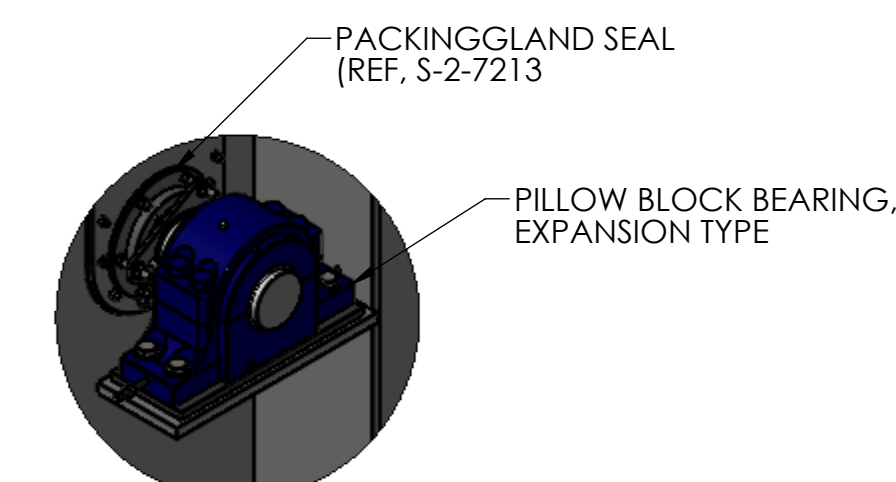

NON DRIVE SIDE DETAIL  
\*NOTE STIFFENER HIDDEN TO SHOW DETAIL\*

MIXER SIZE CU. FT	*STD HP.	A	B	C	D	E	F	G	H	I	STD AGITATOR SPEED RPM
5	1.5	18	36	22	2	16	12	28.5	24.5	4	70
7.5	2	20	42	24	2	17	13	32	28	4	63
10	3	22	48	27	2.5	18	14	36.5	32	4	57
12.5	3	24	48	29	2.5	19	15	36.5	32	4	52
15	5	26	54	31	2.5	20	17	40.25	35.75	6	48
20	5	28	60	33	2.5	21	18	45.25	38.75	6	44
25	7.5	30	60	35	2.5	22	19	45.25	39	6	41
30	7.5	32	66	37	2.5	23	20	48.5	42	6	39
40	7.5	36	72	41	2.5	25	22	51.5	45	8	34
50	10	38	78	43	2.5	26	23	55.5	49	8	32
60	10	40	84	45	2.5	27	24	58.5	52	8	31
75	15	42	96	47	2.5	28	25	66.75	59.75	8	29
100	20	48	96	53	2.5	31	29	67	60	8	26
150	25	54	114	59	2.5	34	33	77.25	70.25	10	23

\* HORSEPOWER BASED ON THE BULK DENSITY OF 45LB/CUFT OF MATERIAL

GENERAL TOLERANCES UNLESS OTHERWISE SPECIFIED THE FOLLOWING SHALL APPLY			
MACHINING	XX= .02	XXX= .005	ANGLES .50°
SURFACE ROUGHNESS HEIGHT	.63 MICRORINCHES OR LESS		
FABRICATION	UNDER 6	6 TO 24	24 TO 60 OVER 60
	± .06	± .12	± .19 ± .25
UNLESS OTHERWISE SPECIFIED DIMENSIONS ARE IN INCHES. UNLESS SPECIFIED DIMENSIONS & TOLERANCES INTERPRETED PER ASME Y14.5-2009.			

REV. NO.	DESCRIPTION	DATE	BY
REVISIONS			
CUSTOMER:			
CUSTOMER PO NUMBER:			
YOUNG JOB NUMBER:			
TITLE			
YOUNG INDUSTRIES 5 THRU 150 CUFT HB MIXERS STANDARD DIMENSION SHEET			
DRAWN BY: SLB		DATE: 07/01/24	
CHECKED BY:		SCALE=1:15	
DRAWING NUMBER	D-21404-01	SHEET	REV:
		1 OF 1	00