

D- NO. & SIZE OF THRU HOLES

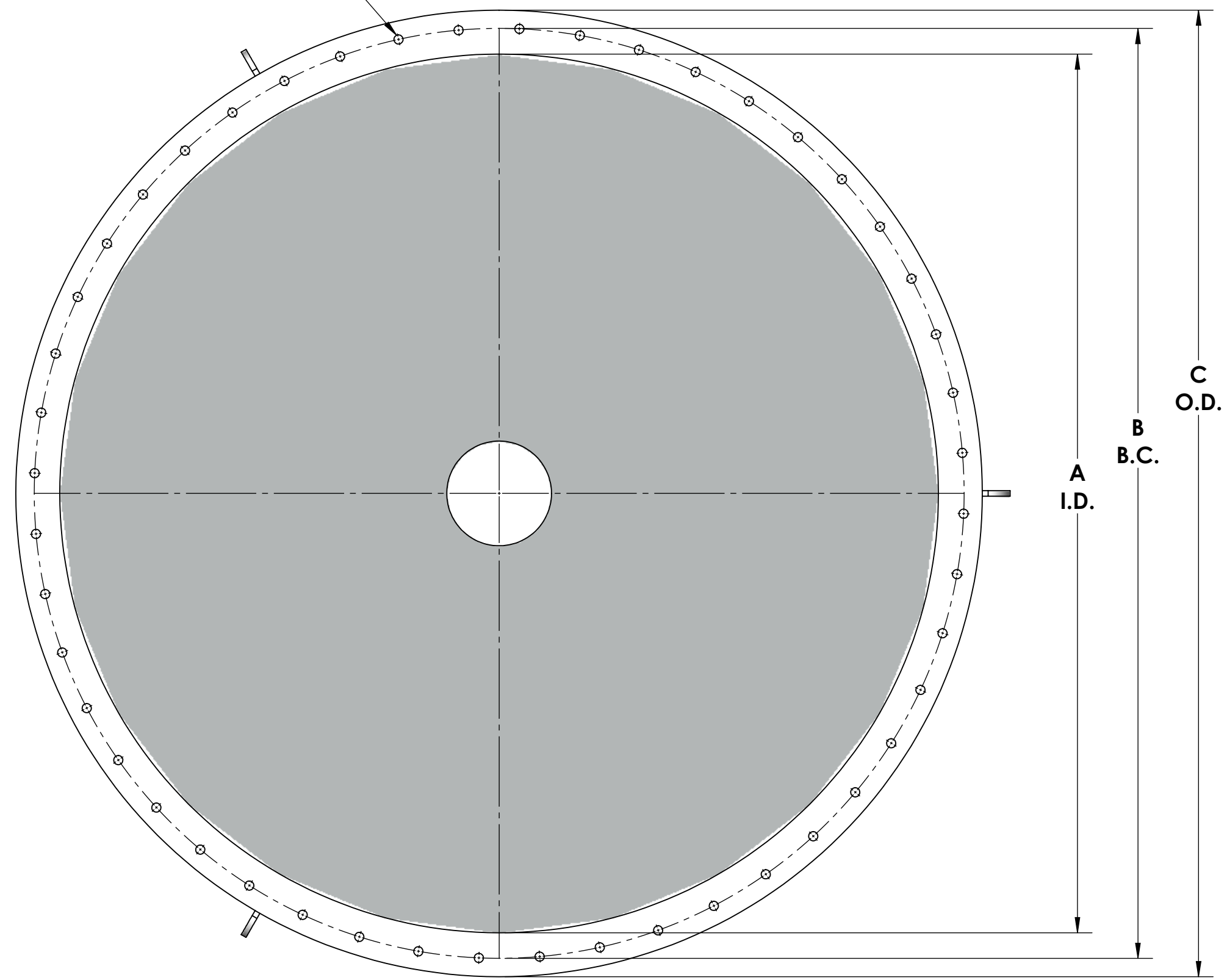

NOTES:

1. SILENTFLOW BIN DISCHARGERS ARE AVAILABLE IN CARBON STEEL AND STAINLESS STEEL. OTHER MATERIALS ARE AVAILABLE UPON REQUEST.
2. TRANSFLOW FLUIDIZATION MEDIA IS CONSTRUCTED OF 316 STAINLESS STEEL.
3. GASKET MATERIAL: NEOPRENE, RTV, OR CUSTOMER SPECIFIED.
4. PAINT SPECIFICATION: YOUNG INDUSTRIES STANDARD 082.500 Y.I. EPOXY OR CUSTOMER SPECIFIED. STAINLESS STEEL IS NOT PAINTED.
5. MOISTURE DRAINS ARE OPTIONAL AND WILL ONLY BE FURNISHED WHEN SPECIFIED.
6. LEVEL INDICATORS ARE OPTIONAL AND WILL ONLY BE FURNISH WHEN SPECIFIED.
7. LIFTING LUGS ARE OPTIONAL AND WILL ONLY BE FURNISH WHEN SPECIFIED.
8. MATERIAL FINISH:
C/S PLATE / SHEET FINISH - HOT ROLLED
S/S SHEET FINISH - NO. 2B
S/S PLATE FINISH - H.R.A.P.

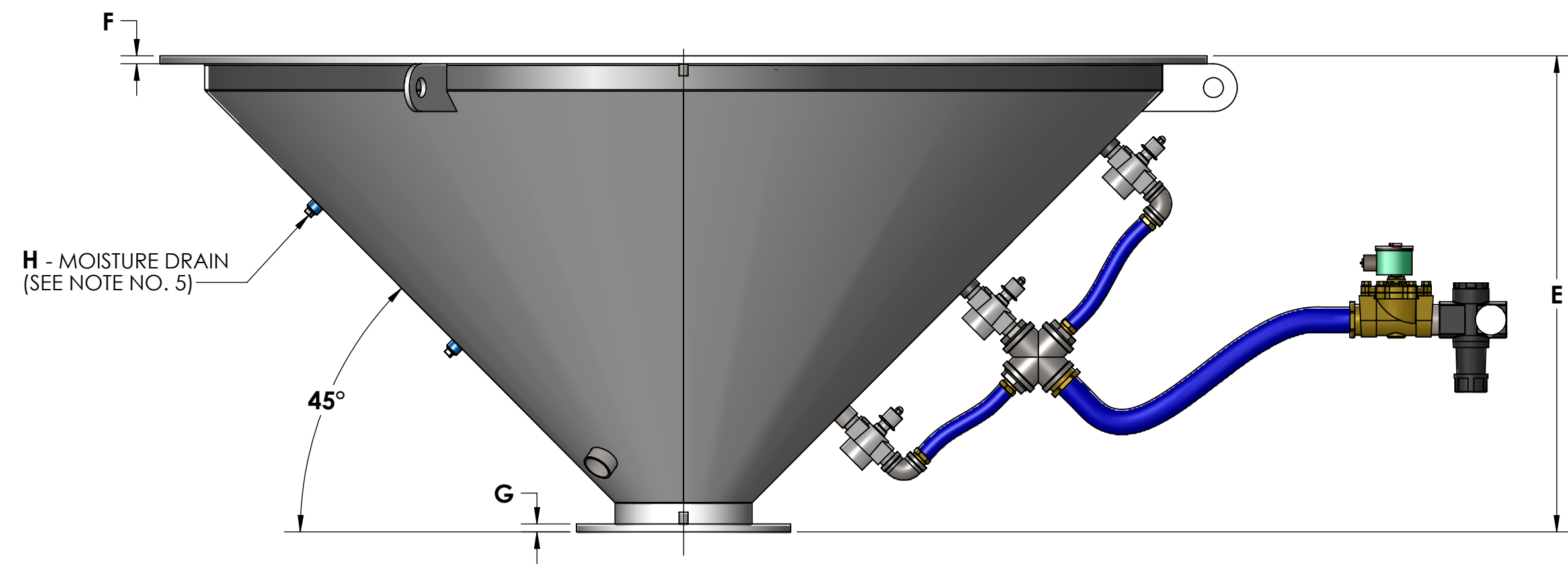
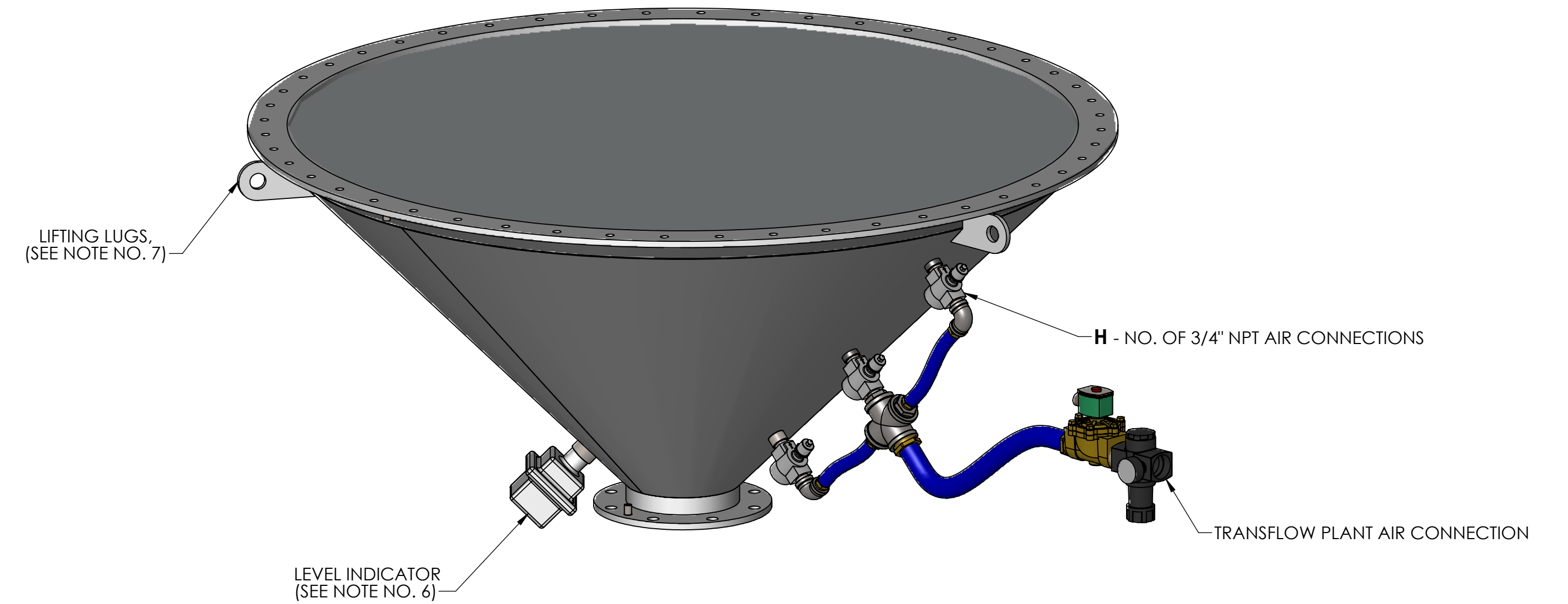

I - NO. & SIZE OF THRU HOLES

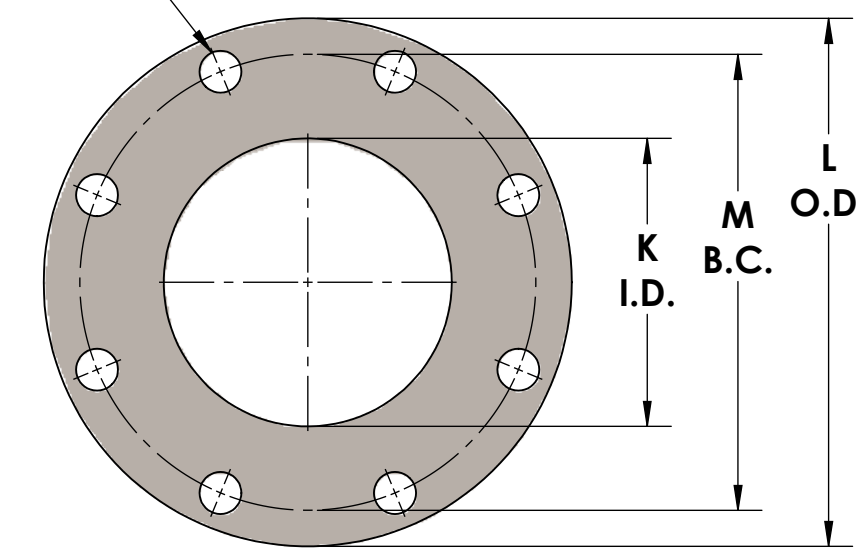

A	B	C	D	E	F	G	H	I	J	K	L	M
18.00	20.25	22.00	(12) .50	10.50	0.50	0.25	1	(8) .75	4.00	3.25	9.00	7.50
24.00	26.25	28.00	(16) .50	12.50	0.50	0.38	1	(8) .88	6.00	5.25	11.00	9.50
36.00	39.50	42.00	(24) .62	18.50	0.50	0.38	2	(8) .88	6.00	5.25	11.00	9.50
48.00	51.50	54.00	(36) .62	24.00	0.50	0.50	2	(8) .88	8.00	7.25	13.50	11.75
60.00	63.50	66.00	(36) .62	30.00	0.50	0.50	3	(8) .88	8.00	7.25	13.50	11.75
72.00	75.50	78.00	(48) .62	36.00	0.50	0.50	3	(8) .88	8.00	7.25	13.50	11.75

REV. NO.	DESCRIPTION	DATE	BY
REVISIONS			
CUSTOMER:			
CUSTOMER PO NUMBER:			
YOUNG JOB NUMBER:			
TITLE			
YOUNG INDUSTRIES 45 DEGREE SILENTFLOW BIN DISCHARGER			
<small>MUNICIPALITY, PENNSYLVANIA 17756 TELEPHONE: 570-546-3165</small>			
DRAWN BY: BWY		DATE: 07/29/24	
CHECKED BY:		SCALE=1:8	
DRAWING NUMBER		SHEET	
D-21404-13		1 OF 1	
		REV: 00	

GENERAL TOLERANCES
UNLESS OTHERWISE SPECIFIED THE FOLLOWING SHALL APPLY
MACHINING - .XX± .02 .XXX± .005 ANGLES - 30°
SURFACE ROUGHNESS HEIGHT 63 MICRONS INCHES OR LESS
FABRICATION - UNDER 6 6 TO 24 24 TO 60 OVER 60
± .06 ± .12 ± .19 ± .25
UNLESS OTHERWISE SPECIFIED DIMENSIONS ARE IN INCHES.
UNLESS SPECIFIED DIMENSIONS & TOLERANCES INTERPRETED
PER ASME Y14.5-2009

3RD