

NOTE: TOP COVER & DRIVE REMOVED FOR CLARITY

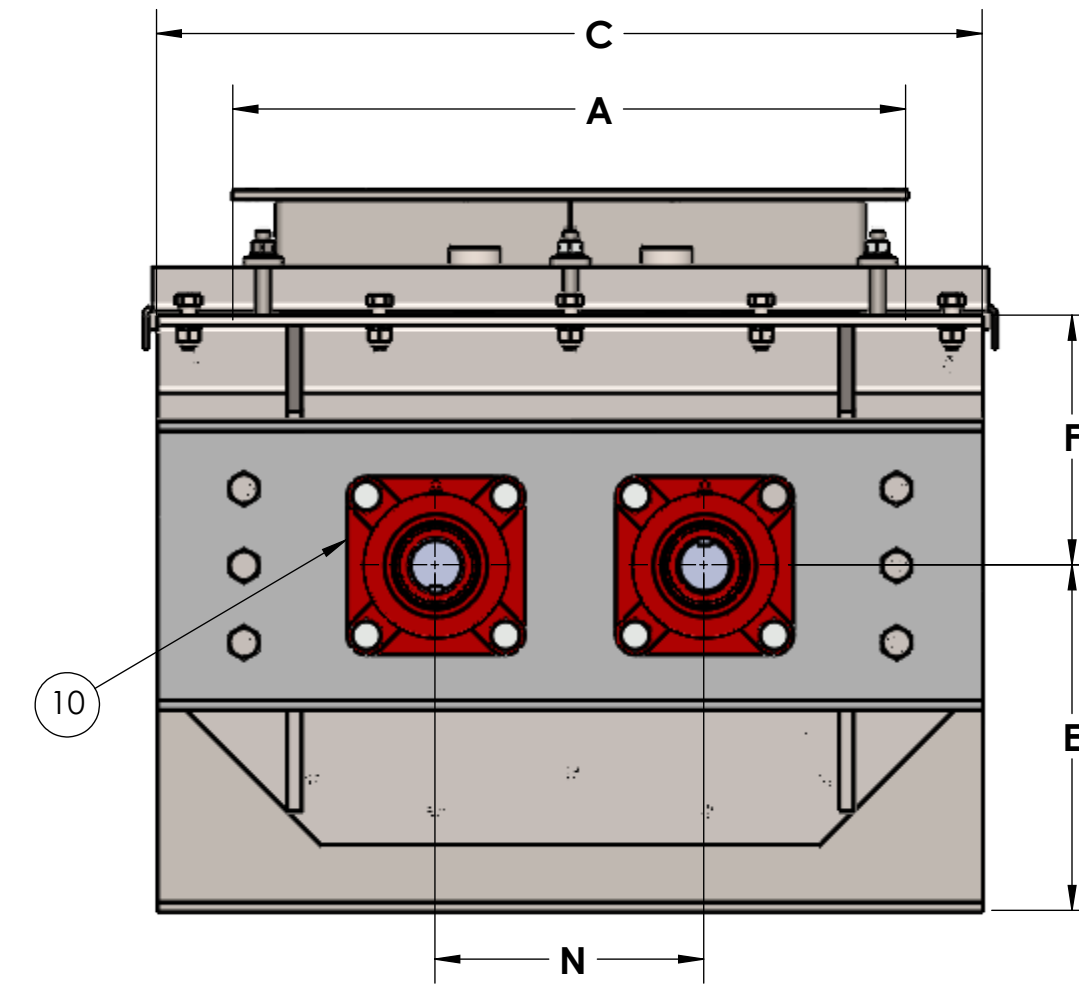
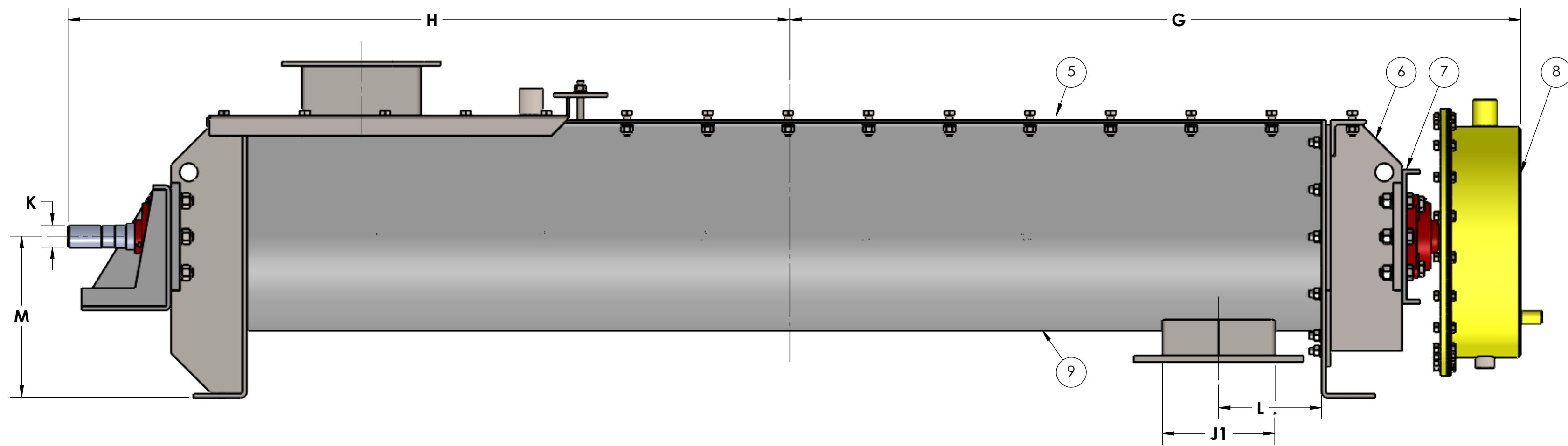
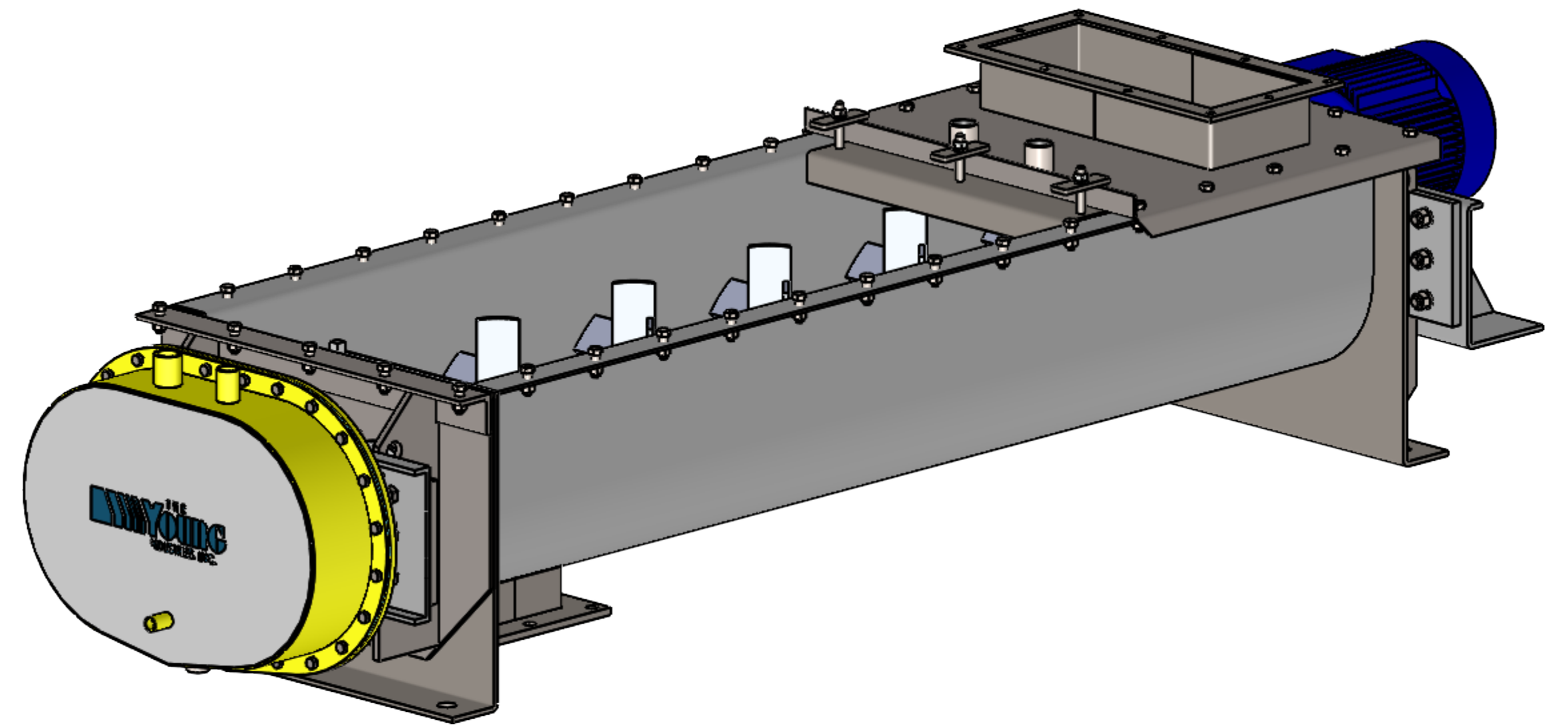

NOTE: GEAR GUARD REMOVED FOR CLARITY

MIXER SIZE	RETAINED VOLUME (CU. FT.)	A	B	C	D	E	F	G	H	J1	J2	K	L	M	N	STD. SPEED (RPM)
15 X 72	10.20	26.50	72.00	31.00	2.00	11.00	11.00	50.38	51.38	10.00	20.00	2.44	7.75	10.00	10.00	155
15 X 84	12.30	26.50	84.00	31.00	2.00	11.00	11.00	56.38	57.38	10.00	20.00	2.44	7.75	10.00	10.00	155
15 X 96	14.40	26.50	96.00	31.00	2.00	11.00	11.00	62.38	63.38	10.00	20.00	2.44	7.75	10.00	10.00	155
15 X 108	16.50	26.50	108.00	31.00	2.00	11.00	11.00	68.38	69.38	10.00	20.00	2.44	7.75	10.00	10.00	155
15 X 120	18.50	26.50	120.00	31.00	2.00	11.00	11.00	74.38	75.38	10.00	20.00	2.44	7.75	10.00	10.00	155
15 X 132	20.60	26.50	132.00	31.00	2.00	11.00	11.00	80.38	81.38	10.00	20.00	2.44	7.75	10.00	10.00	155
18 X 96	17.00	34.50	96.00	40.00	2.50	12.00	13.00	65.88	64.88	12.00	28.00	2.94	8.75	11.00	16.00	125
18 X 120	22.00	34.50	120.00	40.00	2.50	12.00	13.00	77.88	76.88	12.00	28.00	2.94	8.75	11.00	16.00	125
18 X 144	27.00	34.50	144.00	40.00	2.50	12.00	13.00	89.88	88.88	12.00	28.00	2.94	8.75	11.00	16.00	125
18 X 168	32.00	34.50	168.00	40.00	2.50	12.00	13.00	101.88	100.88	12.00	28.00	2.94	8.75	11.00	16.00	125
18 X 192	37.00	34.50	192.00	40.00	2.50	12.00	13.00	113.88	112.88	12.00	28.00	2.94	8.75	11.00	16.00	125
18 X 216	42.00	34.50	216.00	40.00	2.50	12.00	13.00	125.88	124.88	12.00	28.00	2.94	8.75	11.00	16.00	125
21 X 120	29.30	39.50	100.00	45.00	2.50	14.00	16.00	79.88	78.88	14.00	30.00	3.44	9.75	13.00	18.00	110
21 X 144	36.00	39.50	144.00	45.00	2.50	14.00	16.00	91.88	90.88	14.00	30.00	3.44	9.75	13.00	18.00	110
21 X 168	42.80	39.50	168.00	45.00	2.50	14.00	16.00	103.88	102.88	14.00	30.00	3.44	9.75	13.00	18.00	110
21 X 192	49.60	39.50	192.00	45.00	2.50	14.00	16.00	115.88	114.88	14.00	30.00	3.44	9.75	13.00	18.00	110
21 X 216	56.40	39.50	216.00	45.00	2.50	14.00	16.00	127.88	126.88	14.00	30.00	3.44	9.75	13.00	18.00	110
21 X 240	63.20	39.50	240.00	45.00	2.50	14.00	16.00	139.88	138.88	14.00	30.00	3.44	9.75	13.00	18.00	110

NOTE: SPECIFICATIONS SUBJECT TO CHANGE WITHOUT NOTIFICATION

LEGEND

- ① DRIVE MOUNTING SUPPORT BRACKET (DRIVE NOT SHOWN)
- ② TWIN SHAFT MIXER COVER CLAMP BAR
- ③ AGITATOR
- ④ WEIR GATE ASSEMBLY
- ⑤ TWIN SHAFT MIXER COVER
- ⑥ TWIN SHAFT MIXER REMOVABLE END
- ⑦ BEARING MOUNTING PLATE
- ⑧ OIL TIGHT GEAR GUARD
- ⑨ TWIN SHAFT MIXER BODY
- ⑩ BEARING, SEALMASTER

GENERAL TOLERANCES	
UNLESS OTHERWISE SPECIFIED THE FOLLOWING SHALL APPLY	
MACHINING - XX= .02 XXX= .005 ANGLES - 30°	
SURFACE ROUGHNESS HEIGHT .63 MICRONS OR LESS	
FABRICATION - UNDER 6 6 TO 24 24 TO 60 OVER 60	
± .06 ± .12 ± .19 ± .25	
UNLESS OTHERWISE SPECIFIED DIMENSIONS ARE IN INCHES. UNLESS SPECIFIED DIMENSIONS & TOLERANCES INTERPRETED PER ASME Y14.5-2009	
3RD	

REV. NO.	DESCRIPTION	DATE	BY
REVISIONS			
CUSTOMER:			
CUSTOMER PO NUMBER:			
YOUNG JOB NUMBER:			
TITLE			
YOUNG INDUSTRIES CONTINUOUS TWIN SHAFT MIXER W/ WEIR PLATE ASSEMBLY, SIZE 15" X 72" TO 21" X 240"			
STANDARD DIMENSION SHEET			
MUNICIPALITY, PENNSYLVANIA 17756 TELEPHONE: 570-546-3165			
DRAWN BY: JPR		DATE: 08/23/24	
CHECKED BY:		SCALE=1:5	
DRAWING NUMBER		SHEET	
D-21404-33		1 OF 1	
		REV: 00	