

NOTE: TOP COVER & DRIVE REMOVED FOR CLARITY

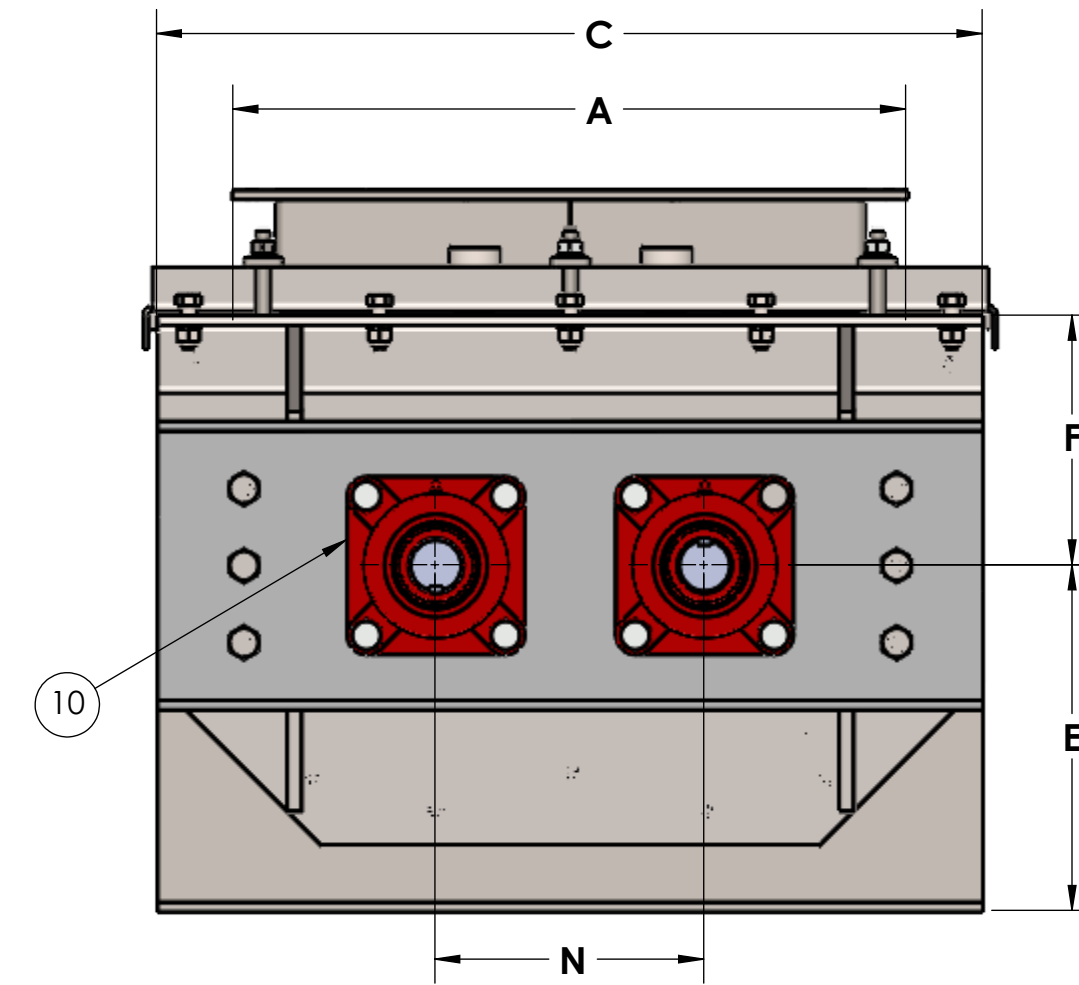
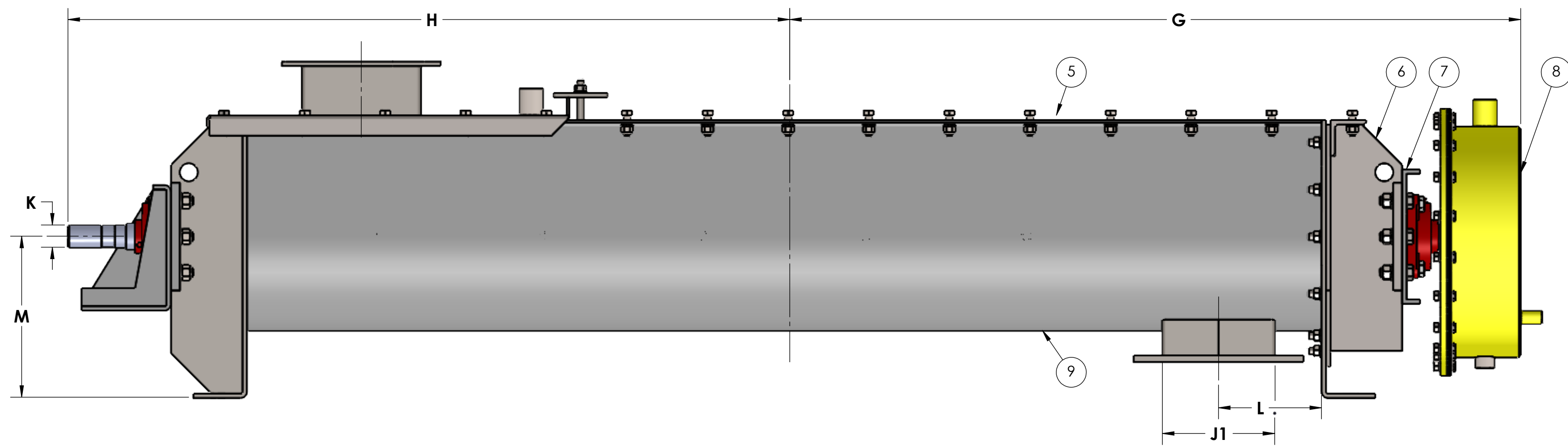
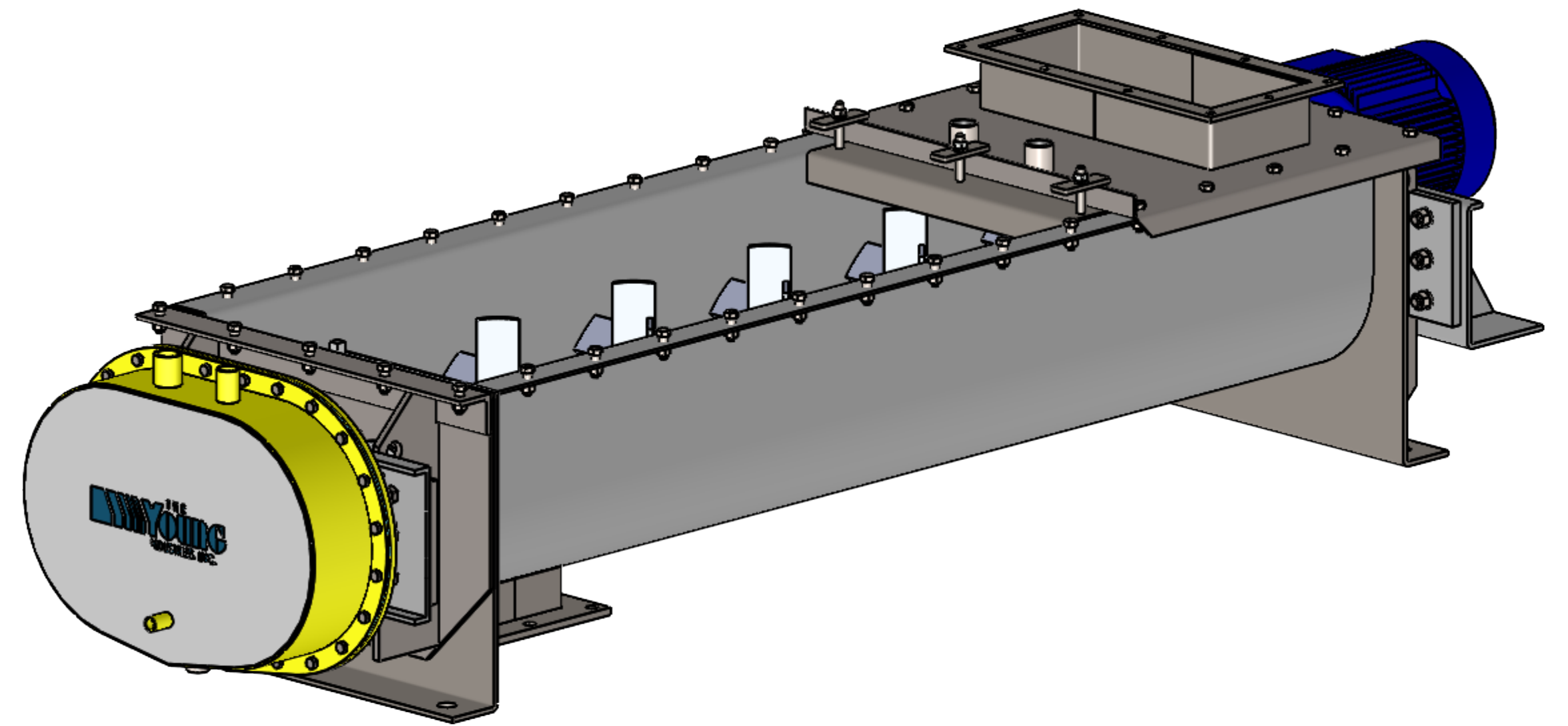

NOTE: GEAR GUARD REMOVED FOR CLARITY

MIXER SIZE	RETAINED VOLUME (CU. FT.)	A	B	C	D	E	F	G	H	J1	J2	K	L	M	N	STD. SPEED (RPM)
24 X 120	39.40	45.50	120.00	52.00	3.00	16.00	18.00	58.13	57.13	15.00	36.00	3.94	10.25	15.00	21.00	85
24 X 144	48.60	45.50	144.00	52.00	3.00	16.00	18.00	70.13	69.13	15.00	36.00	3.94	10.25	15.00	21.00	85
24 X 168	57.90	45.50	168.00	52.00	3.00	16.00	18.00	82.13	81.13	15.00	36.00	3.94	10.25	15.00	21.00	85
24 X 192	67.10	45.50	192.00	52.00	3.00	16.00	18.00	94.13	93.13	15.00	36.00	3.94	10.25	15.00	21.00	85
24 X 216	76.40	45.50	216.00	52.00	3.00	16.00	18.00	106.13	105.13	15.00	36.00	3.94	10.25	15.00	21.00	85
24 X 240	85.62	45.50	240.00	52.00	3.00	16.00	18.00	118.13	117.13	15.00	36.00	3.94	10.25	15.00	21.00	85
30 X 120	62.45	56.50	120.00	63.00	3.00	20.00	22.00	84.38	83.38	16.00	44.00	4.44	10.75	18.00	26.00	65
30 X 144	77.25	56.50	144.00	63.00	3.00	20.00	22.00	96.38	95.38	16.00	44.00	4.44	10.75	18.00	26.00	65
30 X 168	92.05	56.50	168.00	63.00	3.00	20.00	22.00	108.38	107.38	16.00	44.00	4.44	10.75	18.00	26.00	65
30 X 192	106.86	56.50	192.00	63.00	3.00	20.00	22.00	120.38	119.38	16.00	44.00	4.44	10.75	18.00	26.00	65
30 X 216	121.66	56.50	216.00	63.00	3.00	20.00	22.00	132.38	131.38	16.00	44.00	4.44	10.75	18.00	26.00	65
30 X 240	136.46	56.50	240.00	63.00	3.00	20.00	22.00	144.38	143.38	16.00	44.00	4.44	10.75	18.00	26.00	65
36 X 120	91.50	68.50	120.00	75.00	3.00	24.00	26.00	86.13	85.13	18.00	54.00	4.94	11.75	21.00	32.00	60
36 X 144	111.60	68.50	144.00	75.00	3.00	24.00	26.00	98.13	97.13	18.00	54.00	4.94	11.75	21.00	32.00	60
36 X 168	135.70	68.50	168.00	75.00	3.00	24.00	26.00	110.13	109.13	18.00	54.00	4.94	11.75	21.00	32.00	60
36 X 192	157.80	68.50	192.00	75.00	3.00	24.00	26.00	122.13	121.13	18.00	54.00	4.94	11.75	21.00	32.00	60
36 X 216	181.81	68.50	216.00	75.00	3.00	24.00	26.00	134.13	133.13	18.00	54.00	4.94	11.75	21.00	32.00	60
36 X 240	202.10	68.50	240.00	75.00	3.00	24.00	26.00	146.13	145.13	18.00	54.00	4.94	11.75	21.00	32.00	60

NOTE: SPECIFICATIONS SUBJECT TO CHANGE WITHOUT NOTIFICATION

LEGEND

- ① DRIVE MOUNTING SUPPORT BRACKET (DRIVE NOT SHOWN)
- ② TWIN SHAFT MIXER COVER CLAMP BAR
- ③ AGITATOR
- ④ WEIR GATE ASSEMBLY
- ⑤ TWIN SHAFT MIXER COVER
- ⑥ TWIN SHAFT MIXER REMOVABLE END
- ⑦ BEARING MOUNTING PLATE
- ⑧ OIL TIGHT GEAR GUARD
- ⑨ TWIN SHAFT MIXER BODY
- ⑩ BEARING, SEALMASTER

GENERAL TOLERANCES	
UNLESS OTHERWISE SPECIFIED THE FOLLOWING SHALL APPLY	
MACHINING - XX= .02 XXX= .005 ANGLES - 30°	
SURFACE ROUGHNESS HEIGHT .63 MICRONS OR LESS	
FABRICATION - UNDER 6" 6 TO 24" 24 TO 60" OVER 60"	
±.06 ±.12 ±.19 ±.25	
UNLESS OTHERWISE SPECIFIED DIMENSIONS ARE IN INCHES. UNLESS SPECIFIED DIMENSIONS & TOLERANCES INTERPRETED PER ASME Y14.5-2009	
3RD	

REV. NO.	DESCRIPTION	DATE	BY
REVISIONS			
CUSTOMER:			
CUSTOMER PO NUMBER:			
YOUNG JOB NUMBER:			
TITLE			
YOUNG INDUSTRIES CONTINUOUS TWIN SHAFT MIXER W/ WEIR PLATE ASSEMBLY, SIZE 24" X 120" TO 36" X 240"			
STANDARD DIMENSION SHEET			
MUNICIPALITY, PENNSYLVANIA 17756			
TELEPHONE: 570-546-3165			
DRAWN BY: JPR		DATE: 08/23/24	
CHECKED BY:		SCALE: 1:5	
DRAWING NUMBER		SHEET	
D-21404-34		1 OF 1	
		REV: 00	