

SIZE	A	B	C	D	E	F	G	H	I	J	K	L
25"	25.00	12.50	16.50	29.00	30.00	20.00	7.00	6.00	4.00	22.89	29.63	68.50
32"	32.00	16.00	16.50	31.00	30.00	20.00	7.00	6.00	4.00	29.89	29.63	70.50
38"	38.00	19.00	20.00	42.00	38.00	25.50	8.00	7.00	4.00	35.89	35.63	78.00
45"	45.00	22.50	20.00	42.00	38.00	25.50	8.00	7.00	4.00	42.89	35.63	78.00

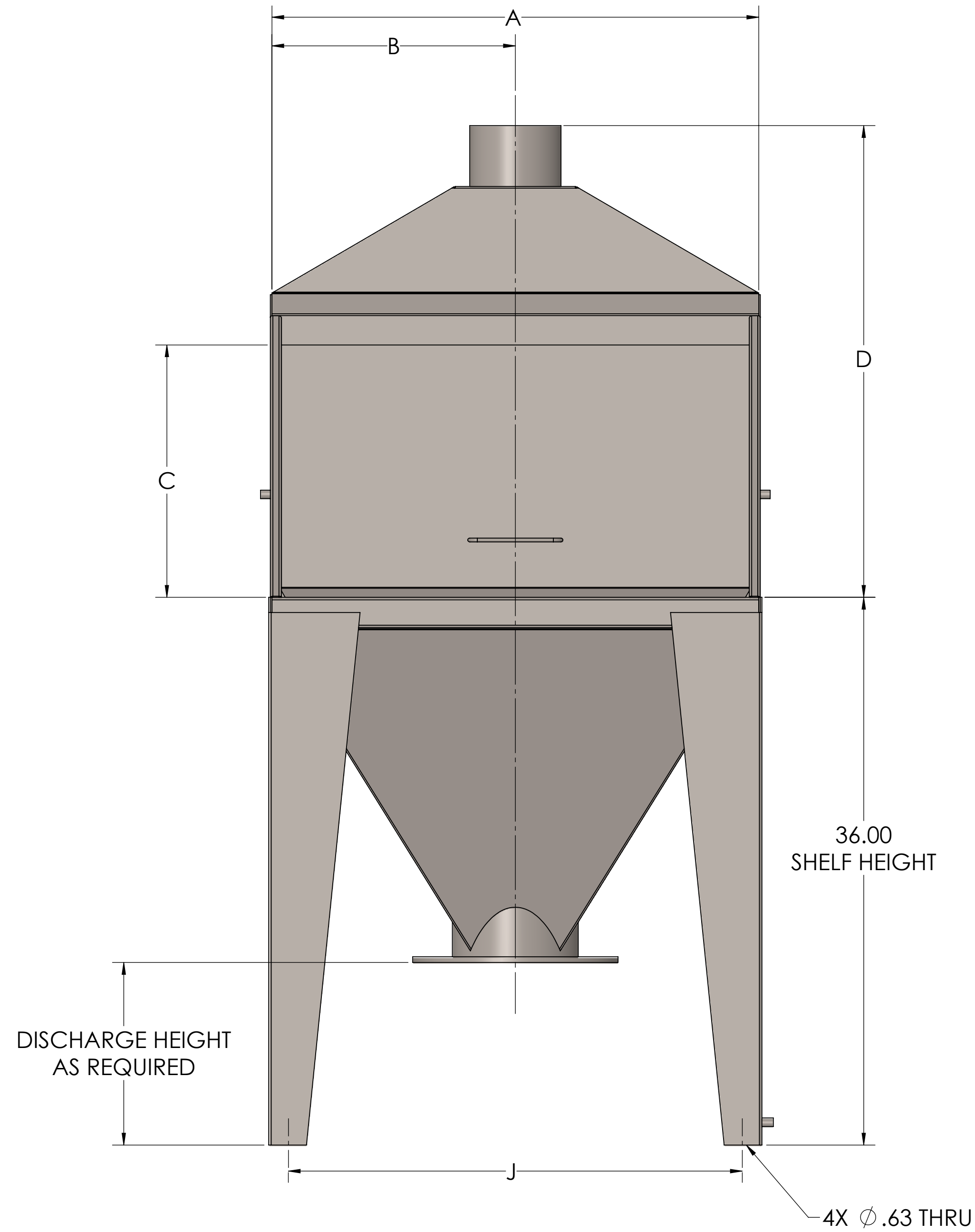

NOTE: CHARGE DOOR HIDDEN FOR CLARITY

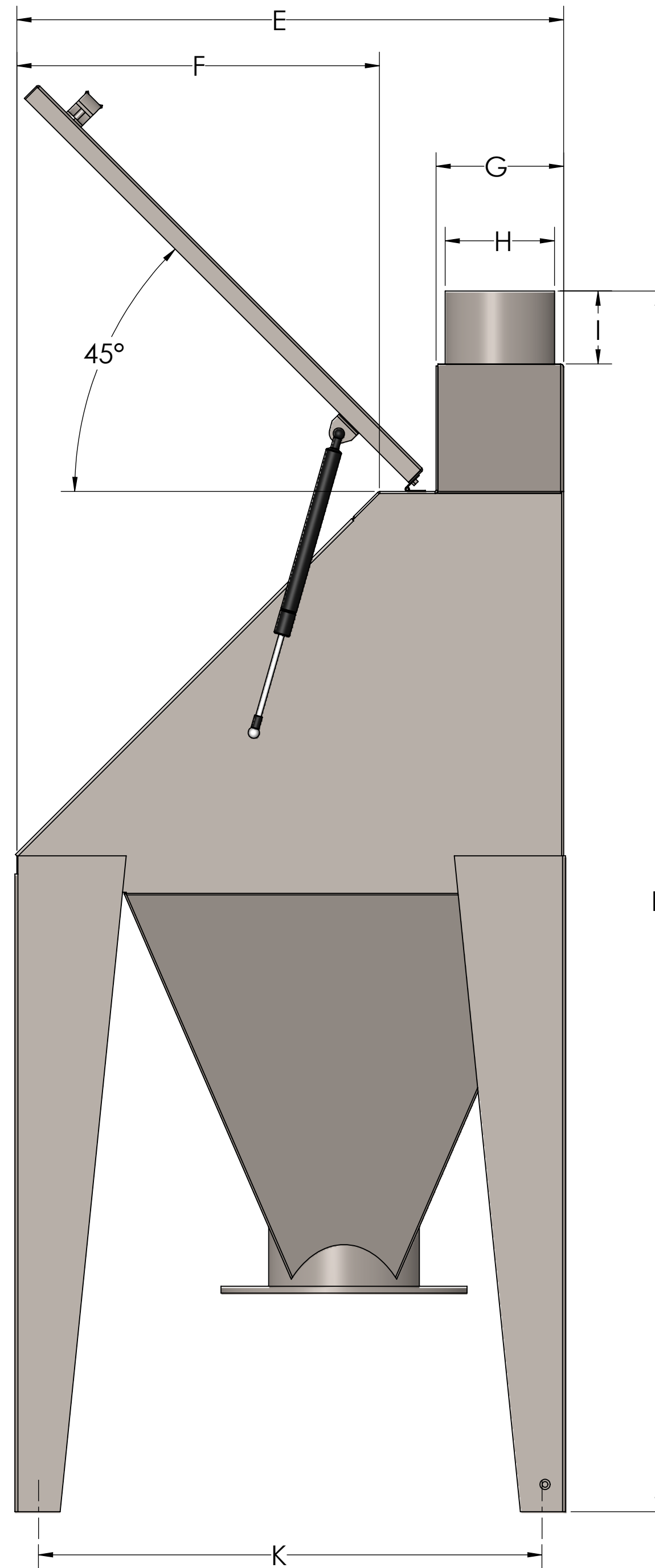

CHARGE DOOR (OPTIONAL)

VENT CONNECTION

BAFFLE (REMOVABLE)

BAG GRATE (REMOVABLE)

DISCHARGE FLANGE (SIZED AS REQUIRED)

REV. NO.	DESCRIPTION	DATE	BY
REVISIONS			
CUSTOMER:			
CUSTOMER PO NUMBER:			
YOUNG JOB NUMBER:			
TITLE			
YOUNG INDUSTRIES VENTED BAG DUMP STATION			



GENERAL TOLERANCES UNLESS OTHERWISE SPECIFIED THE FOLLOWING SHALL APPLY			
MACHINING	±.02	±.005	ANGLES: 30°
SURFACE ROUGHNESS HEIGHT: 63 MICRONS OR LESS			
FABRICATION - UNDER 6	6 TO 24	24 TO 60	OVER 60
±.06	±.12	±.19	±.25
UNLESS OTHERWISE SPECIFIED DIMENSIONS ARE IN INCHES. UNLESS SPECIFIED DIMENSIONS & TOLERANCES INTERPRETED PER ASME Y14.5-2009			

DRAWN BY: JPR	DATE: 01/16/25
CHECKED BY:	SCALE: 1:6
DRAWING NUMBER: D-21404-41	SHEET 1 OF 1
REV: 00	

