

REMOVABLE LIFTING BRACKET
3000 LB LOAD CAPACITY

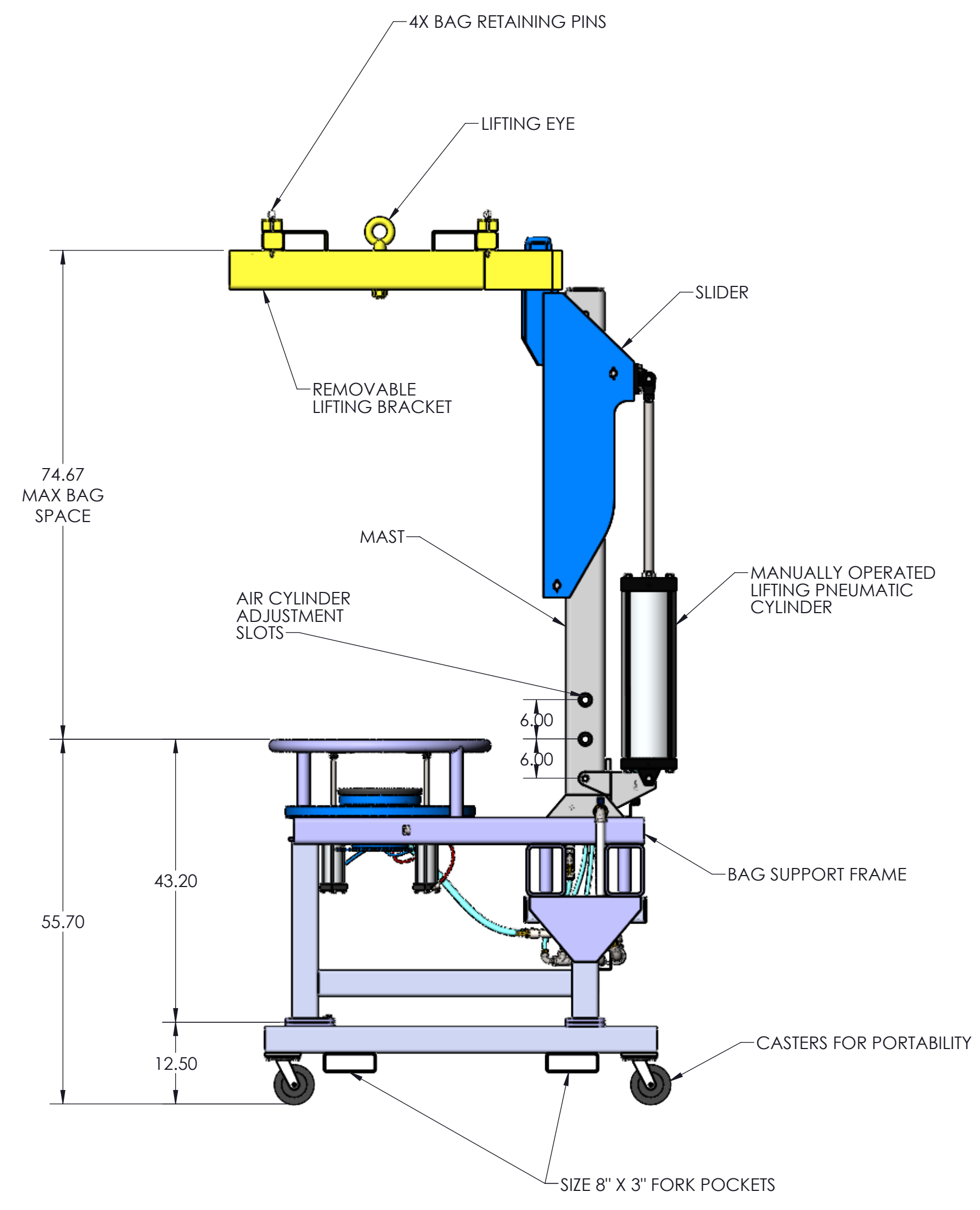
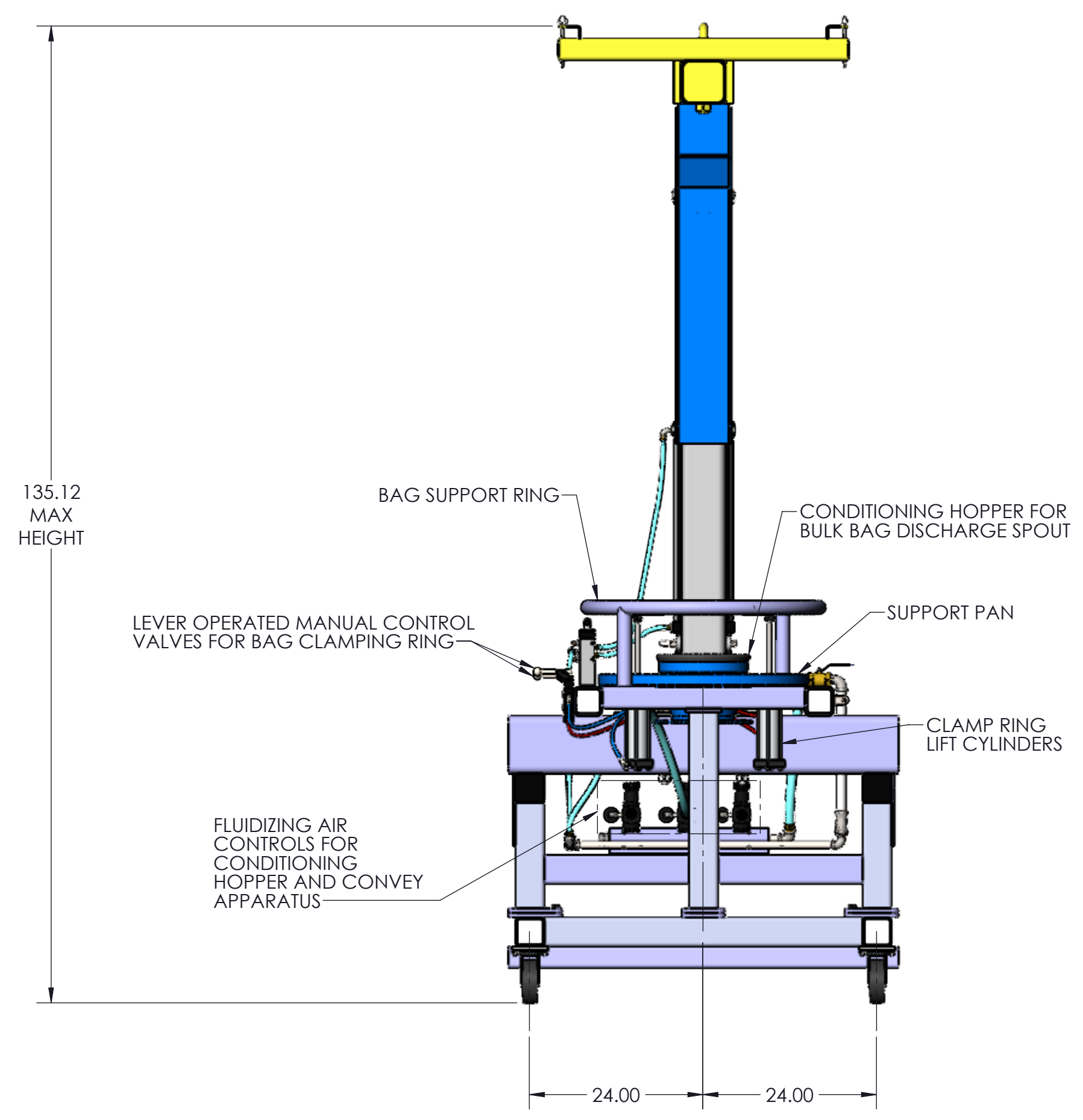
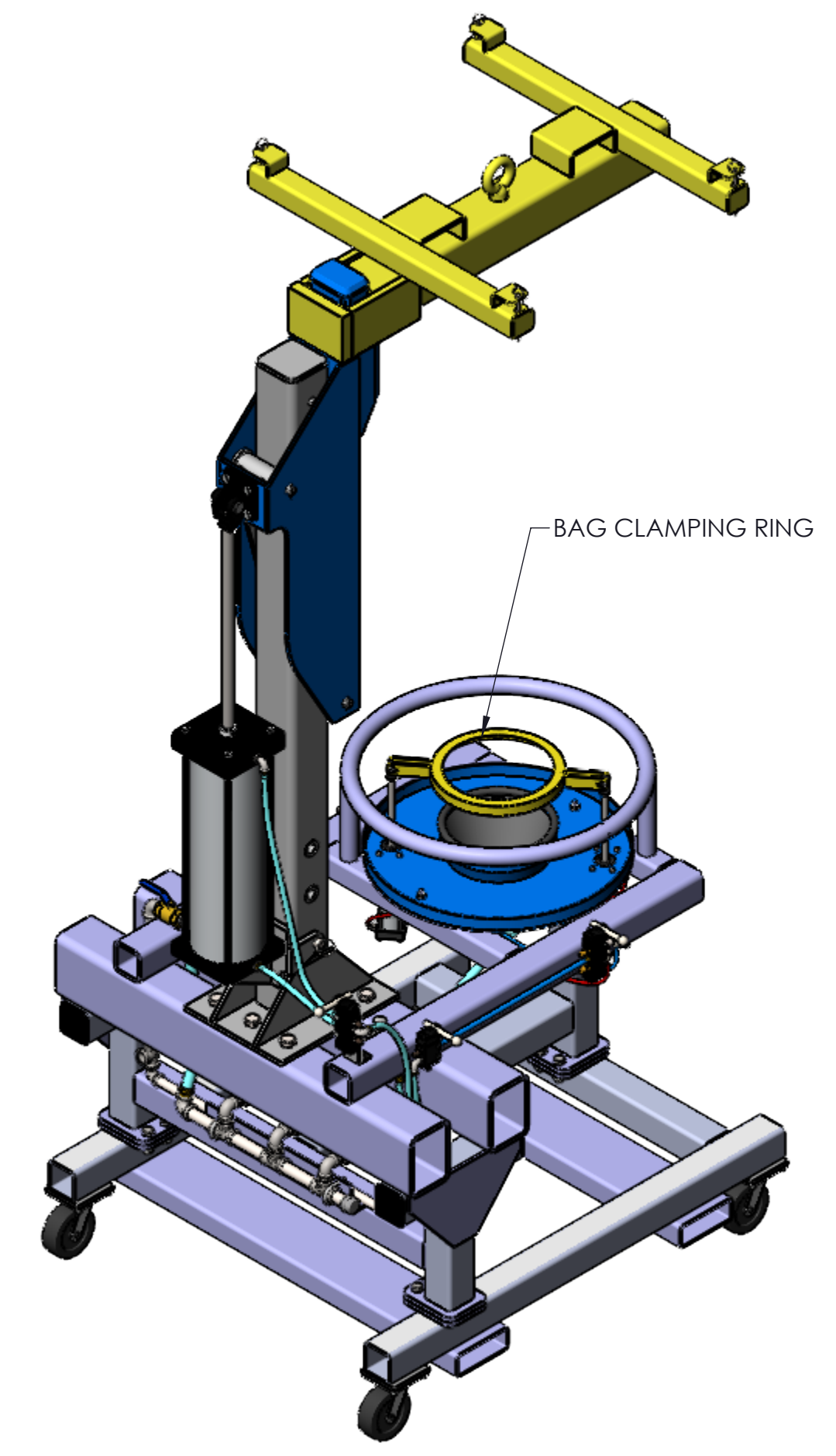

GENERAL TOLERANCES
UNLESS OTHERWISE SPECIFIED THE FOLLOWING SHALL APPLY

MACHINING - XX± .02 XXX± .005 ANGLES - 30°
SURFACE ROUGHNESS HEIGHT 32 MICRONS OR LESS

FABRICATION - UNDER 6 6 TO 24 24 TO 60 OVER 60
± .06 ± .12 ± .19 ± .25

UNLESS OTHERWISE SPECIFIED DIMENSIONS ARE IN INCHES.
UNLESS SPECIFIED DIMENSIONS & TOLERANCES INTERPRETED
PER ASME Y14.5-2009

3RD

REV. NO.	DESCRIPTION	DATE	BY
REVISIONS			
CUSTOMER:			
CUSTOMER PO NUMBER:			
YOUNG JOB NUMBER:			
TITLE			
YOUNG INDUSTRIES DIRECT FROM BAG UNLOADER, PORTABLE, NO CONVEY SYSTEM			
DRAWN BY: MEA		DATE: 01/28/25	
CHECKED BY:		SCALE=1:16	
DRAWING NUMBER		SHEET	REV:
D-21404-48		1 OF 1	00