

ROTOR SIZES: 4"-12" 8-VANE
14"-24" 12-VANE

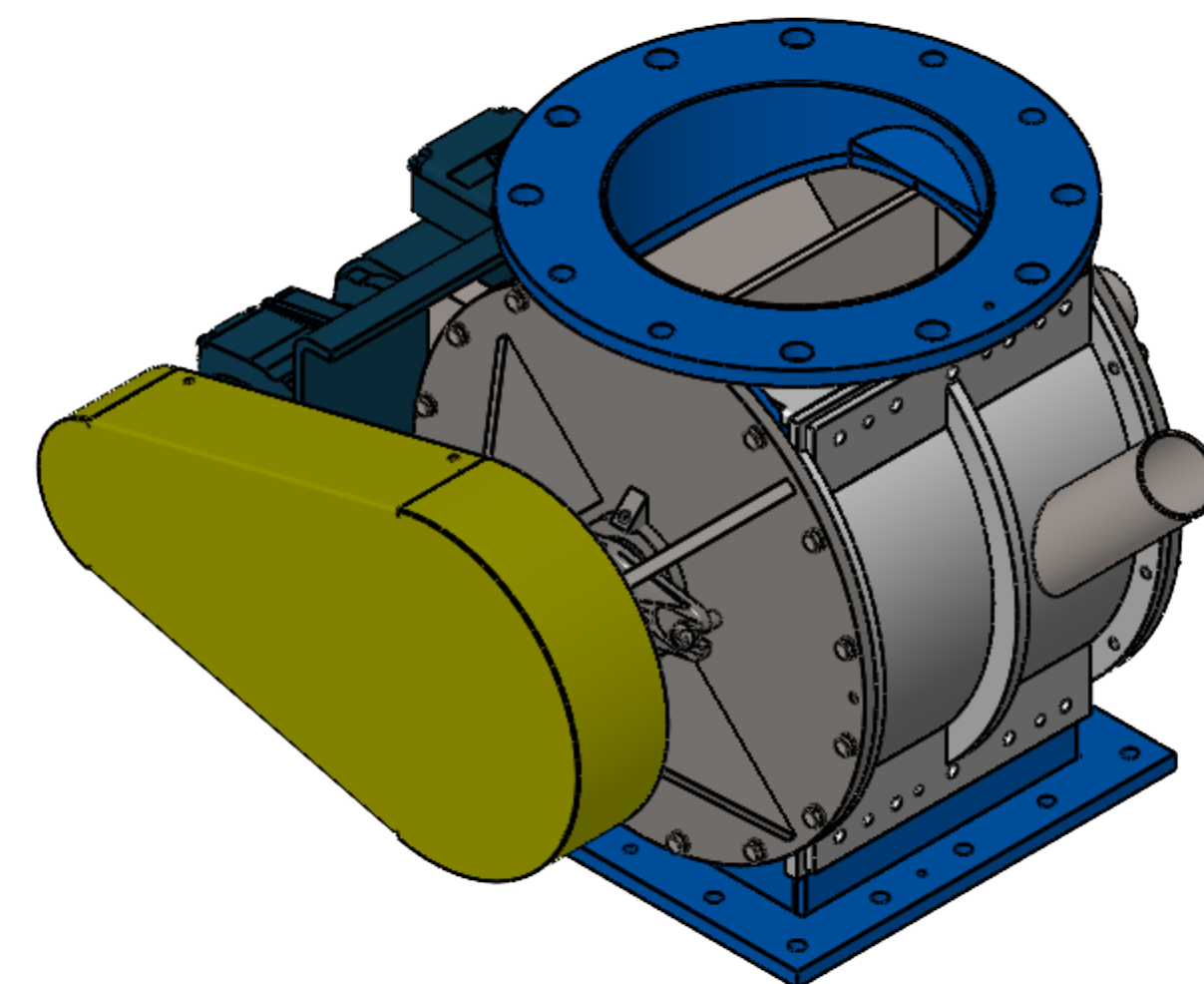
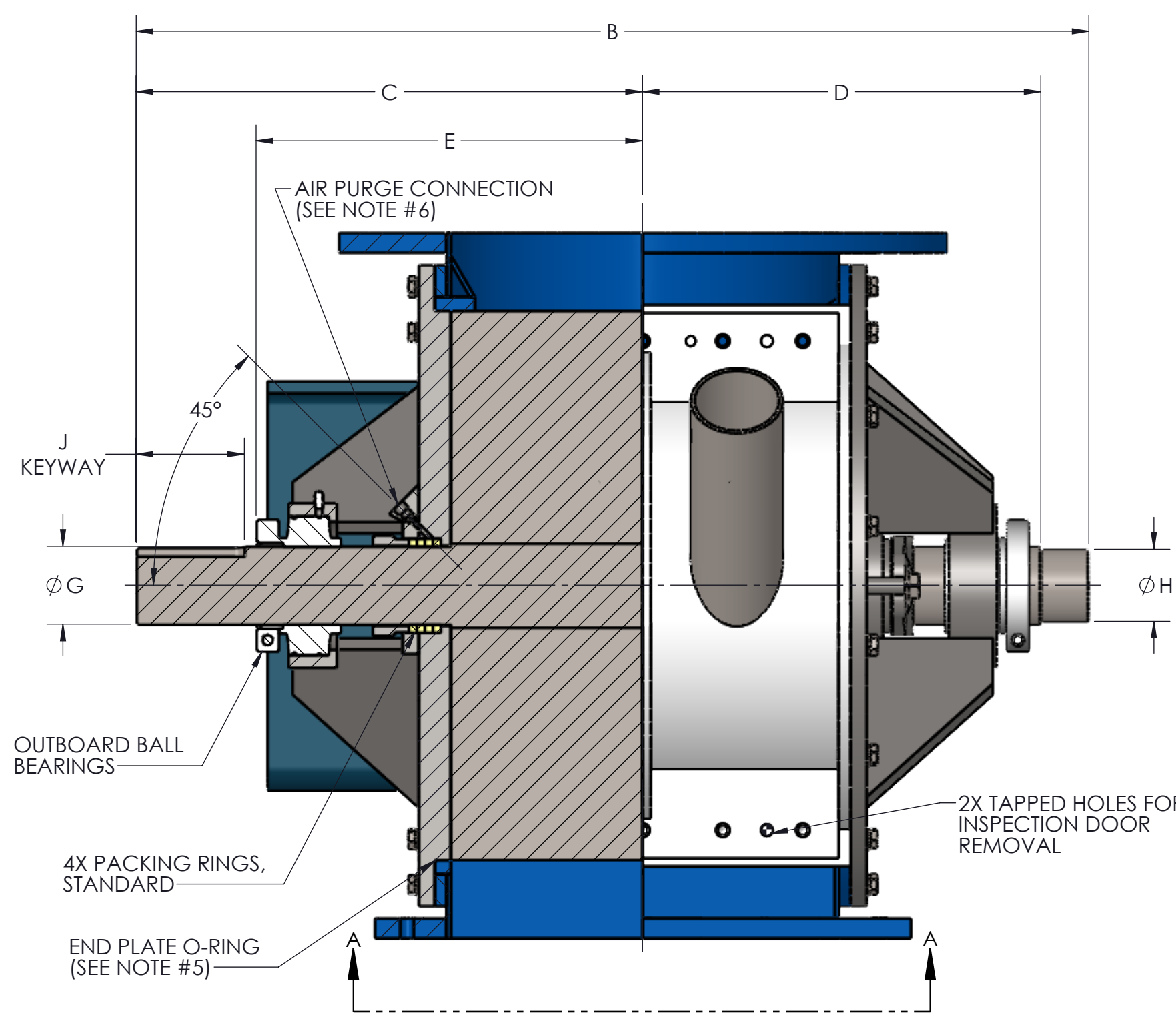
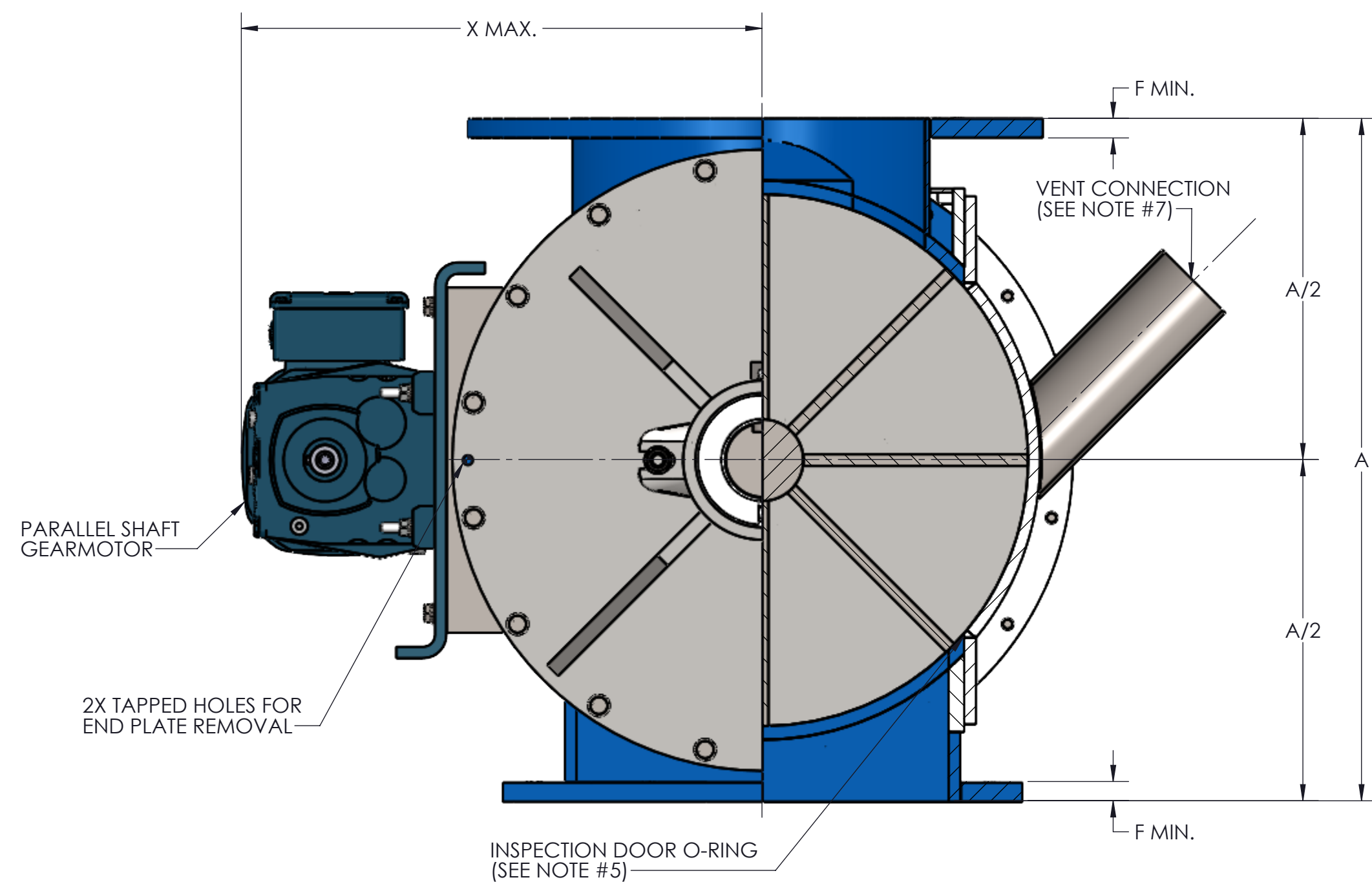

- NOTES:
1. VALVE HOUSINGS ARE CAST OF IRON, ALUMINUM, STEEL OR STAINLESS STEEL; FABRICATED OF STEEL OR STAINLESS STEEL. ALL ROTORS ARE FABRICATED OF STEEL OR STAINLESS STEEL.
 2. VALVE HOUSINGS ARE AVAILABLE WITH EITHER A SQUARE OR ROUND INLET AND OUTLET. ROUND FLANGES MATCH 150# ANSI DRILLING.
 3. STANDARD HOUSINGS ARE DESIGNED FOR 15 PSI (MAX) INTERNAL & DIFFERENTIAL @ 250 DEGREES F.
 4. INSPECTION DOOR IS OPTIONAL AND WILL BE FURNISHED ONLY WHEN SPECIFIED.
 5. END PLATES AND INSPECTION DOOR O-RINGS ARE OPTIONAL AND WILL BE FURNISHED ONLY WHEN SPECIFIED.
 6. AIR PURGE CONNECTIONS WITH BRASS LANTERN RINGS ARE OPTIONAL AND WILL BE FURNISHED ONLY WHEN SPECIFIED.
 7. VENT WITH SCH 10 PIPE IS OPTIONAL AND WILL BE FURNISHED ONLY WHEN SPECIFIED. VENT CONNECTION WILL CHANGE ROTOR ROTATION TO COUNTER-CLOCKWISE

SIZE	ROTOR DIA. X LG.	ROTOR CAPACITY (CU. FT. PER REV.)					STD RPM	VENT SIZE	STD HP	A	B	C	D	E	F	G	H	J	K	L	M	N	P	Q	R	S	T	U	V	W	X	WEIGHT C/S					
		A	B	C	D	D3																															
4	6 X 4	.0528	.0342	.0162	.048	.0488	38	1.25	.50	10.00	19.25	10.31	7.69	7.31	.31	1.19	1.00	.25	X .12 X 2.62	9.00	7.50	4.00	(8)	.75	N/A	7.50	4.00	.62	3.12	N/A	(6)	.56	(2)	.50-13UNC-2B	13.31	205	
5	8 X 5	.123	.0763	.0525	.117	.112	38	1.50	.50	12.00	20.50	10.94	8.31	7.94	.44	1.44	1.25	.38	X .19 X 2.62	10.00	8.50	5.00	(4)	.88	(4)	.75-10UNC-2B	8.50	5.00	.62	3.62	N/A	(6)	.56	(2)	.50-13UNC-2B	14.31	260
6	10 X 6	.237	.142	.092	.230	.218	32	1.50	.50	14.00	22.38	11.88	9.25	8.88	.44	1.94	1.75	.50	X .25 X 2.62	11.00	9.50	6.00	(4)	.88	(4)	.75-10UNC-2B	9.50	6.00	.62	4.12	N/A	(6)	.56	(2)	.50-13UNC-2B	15.38	310
8	12 X 8	.441	.244	.132	.434	.412	32	2.00	.75	17.00	24.38	12.88	10.25	9.88	.44	1.94	1.75	.50	X .25 X 2.62	13.50	11.75	8.00	(4)	.88	(4)	.75-10UNC-2B	11.50	8.00	.62	5.12	2.56	(14)	.56	(2)	.50-13UNC-2B	16.38	385
10	15 X 10	.893	.563	.172	.884	.838	32	2.50	.75	20.00	26.62	13.88	11.25	10.88	.44	2.19	2.00	.50	X .25 X 2.62	16.00	14.25	10.00	(8)	1.00	(4)	.88-9UNC-2B	14.75	10.00	1.00	6.38	3.19	(14)	.56	(2)	.50-13UNC-2B	18.00	520
12	17 X 12	1.398	.730	.284	1.387	1.316	32	2.50	.75	22.00	29.75	15.81	12.44	12.06	.56	2.44	2.25	.62	X .31 X 3.38	19.00	17.00	12.00	(8)	1.00	(4)	.88-9UNC-2B	16.75	12.00	1.00	7.38	3.69	(14)	.56	(2)	.50-13UNC-2B	19.00	660
14	19 X 13	1.787	1.004	.468	1.769	1.651	32	3.00	.75	24.00	30.75	16.31	12.94	12.56	.56	2.44	2.25	.62	X .31 X 3.38	21.00	18.75	13.00	(8)	1.12	(4)	1.00-8UNC-2B	18.00	13.00	1.00	8.00	4.00	(14)	.56	(2)	.50-13UNC-2B	19.94	885
16	23 X 15	3.044	1.679	.777	3.008	2.829	30	3.50	1.5	28.00	34.62	18.31	14.81	14.44	.62	2.94	2.75	.75	X .38 X 3.50	23.50	21.25	15.00	(12)	1.12	(4)	1.00-8UNC-2B	20.00	15.00	1.00	9.00	4.50	(14)	.69	(2)	.62-11UNC-2B	23.00	1260
18	25 X 17	4.125	2.251	1.064	4.102	3.849	28	3.50	1.5	30.00	36.62	19.31	15.81	15.44	.62	2.94	2.75	.75	X .38 X 3.50	25.00	22.75	17.00	(12)	1.25	(4)	1.12-7UNC-2B	22.00	17.00	1.00	10.00	5.00	(14)	.69	(2)	.62-11UNC-2B	24.06	1510
20	28 X 19	5.922	3.234	1.524	5.904	5.572	28	4.00	2.0	36.00	41.38	22.38	17.50	17.12	.75	3.19	3.25	.75	X .38 X 3.50	27.50	25.00	19.00	(16)	1.25	(4)	1.12-7UNC-2B	25.50	19.00	1.25	11.50	5.75	(14)	.81	(2)	.75-10UNC-2B	26.62	2200
22	32 X 21	8.691	4.781	2.257	8.672	8.228	26	5.00	2.0	40.00	45.75	24.81	19.44	19.06	.75	3.69	3.75	.88	X .44 X 5.00	29.75	27.25	21.00	(16)	1.38	(4)	1.25-7UNC-2B	27.50	21.00	1.25	12.50	6.25	(14)	.81	(2)	.75-10UNC-2B	28.62	2730
24	34 X 23	10.833	5.926	2.751	10.772	10.224	24	5.00	2.0	42.00	47.75	25.81	20.44	20.06	.75	3.75	3.75	.88	X .44 X 5.00	32.00	29.50	23.00	(16)	1.38	(4)	1.25-7UNC-2B	29.50	23.00	1.25	13.50	6.75	(14)	.81	(2)	.75-10UNC-2B	29.62	3000

GENERAL TOLERANCES
UNLESS OTHERWISE SPECIFIED THE FOLLOWING SHALL APPLY
MACHINING - .XX" .02 .XXX" .005 ANGLES .50"
SURFACE ROUGHNESS HEIGHT .63 MICRONS OR LESS
FABRICATION - UNDER 6" 6 TO 24" 24 TO 60" OVER 60"
±.06 ±.12 ±.19 ±.25
UNLESS OTHERWISE SPECIFIED DIMENSIONS ARE IN INCHES.
UNLESS SPECIFIED DIMENSIONS & TOLERANCES INTERPRETED
PER ASME Y14.5-2009

3RD

REV. NO.	DESCRIPTION	DATE	BY
REVISIONS			
CUSTOMER:			
CUSTOMER PO NUMBER:			
YOUNG JOB NUMBER:			
TITLE			
YOUNG INDUSTRIES MODEL 'HC' ROTARY VALVE, SIZE 4"-24" CLASS 15 W/ PARALLEL SHAFT DRIVE, OPEN ROTOR STANDARD DIMENSION SHEET			
DRAWN BY: MEA			
DATE: 07/22/24			
CHECKED BY:			
SCALE=1:4			
DRAWING NUMBER			
D-21404-04			
SHEET 1 OF 1			
REV: 00			

YOUNG INDUSTRIES
MUNCY, PENNSYLVANIA 17756
TELEPHONE: 570-546-3165