

GRAVITY DIVERTER VALVES

MODELS: TDV, BDV & VT Installation, Operation, and Maintenance Manual

Tab Diverter Valve
(TDV)



Bucket Diverter Valve
(BDV)

Rotary Vane Diverter
Valve (VT)



INDUSTRIES, INC.
16 PAINTER STREET
MUNCY, PA 17756

FOREWORD

This manual contains instructions for installation, operation and maintenance of Young Industries Gravity Diverter Valves. The care taken during receiving, storage, installation and continued maintenance will add to the reliable operation and long service life of this equipment.

plant safety prior to performing any work on or operating a Gravity Diverter Valve. Contact Young Industries for additional copies which may be required to insure the valve is being operated safely and according to the recommended procedures included in this manual.

This manual should be read and understood in its entirety by the operator and the director of

TABLE OF CONTENTS

FOREWORD.....2
SAFETY3
INSTALLATION.4
 Receiving and Inspection.....4
 Supports5
 Assembly5
 Electrical Installation.....5
 Compressed Gas Installation.5
 Precommissioning.....5
OPERATION6
 Start-Up.6
 Continuous Operation.....6
 Shut Down.6
MAINTENANCE.7
 Lubrication.7
 Drive7
 Bearings and Seals.....7
 General Inspection.....7
 Troubleshooting.7
SPARE PARTS INFORMATION.....7

LIST OF TABLES

TABLE ONE-TROUBLESHOOTING GRAVITY DIVERTER VALVES. 8

LIST OF FIGURES

FIGURE ONE-TAB DIVERTER VALVE EXPLODED VIEW 9
FIGURE TWO-BUCKET DIVERTER VALVE EXPLODED VIEW..... 10
FIGURE THREE-ROTARY VANE DIVERTER VALVE
 EXPLODED VIEW 11
FIGURE FOUR-ROTARY VANE DIVERTER VALVE (SHROUDED
 GATE) EXPLODED VIEW 12

SAFETY

READ AND FULLY UNDERSTAND THIS MANUAL BEFORE OPERATING OR PERFORMING ANY WORK ON A GRAVITY DIVERTER VALVE.

Notify Young Industries if your diverter valve does not include safety warning labels or devices recommended within this manual, which you believe may be important to improve the safe operation or maintenance of your diverter valve installation. Contact the Engineering Manager for assistance at (570) 546-3165 prior to continued use or maintenance.

Safety is a fundamental factor that must be considered at all times in the operation and maintenance of mechanical equipment. Use of proper tools and methods can prevent serious accidents that may result in injury to you and your fellow workers.

A number of safety precautions are listed throughout this manual. Study them carefully and follow them; insist that those working with you do the same. Remember: an accident can easily be caused by someone's carelessness or negligence.

The various precautions and recommendations detailed within this manual are not necessarily all-inclusive. Young Industries has attempted to provide SAFETY AND OPERATIONAL GUIDANCE relating to typical installations with which we are familiar. We urge you to review your particular valve installation to determine whether there are potential hazards beyond the warnings of this manual.

If you have any safety or operational questions pertaining to the design or application of a Young diverter valve as it relates to your particular installation, please contact the Engineering Manager at (570) 546-3165.

Failure to observe and follow the safety precautions may result in serious personal injury or property damage.

Young Industries looks to our customers to achieve a cooperative effort for the purpose of making each valve installation as safe for the operator as is reasonably possible and to insure proper maintenance and operating procedures are followed.

Many times we do not have access to the installation; therefore, your participation in the safe installation, operation and maintenance of each valve is critical.

WARNING ELECTRICAL GROUNDING AND BONDING ARE REQUIRED

Ungrounded machinery presents a potential hazard of fatal electrical shock from electrical power sources. Static electricity may also accumulate on ungrounded/unbonded equipment. Static electricity discharge from ungrounded equipment or between unbonded pieces of equipment may cause explosion or fire if flammable vapor or dust is present.

Electrical equipment must be installed by a certified professional electrician.

Before operating the equipment described by this manual or any other equipment in the same processing system, grounding and bonding must be completed in accordance with the National Electrical Code (NFPA 70) published by the National Fire Protection Association, 1 Batterymarch Park, Quincy, Mass. 02269-9101, and any other applicable National, State or Municipal codes. Codes for safe control of static electricity must also be observed, including the National Fire Code Recommended Practice on Static Electricity (NFPA 77) and any other applicable National, State or Municipal codes.

To avoid hazardous static discharge, mobile, movable or portable equipment which may attach to or come near to other equipment and which is not prohibited by codes from being connected to ground must be safely grounded and bonded before close approach or contact is made. This warning also applies to movable containers such as drums, totes, boxes and bags.

Sections of pipe, duct and gravity spout must be bonded to adjacent sections and must have a conductive path to electrical ground.

Regular periodic safety inspections of electrical systems and grounding/bonding systems are required.

INSTALLATION

A. RECEIVING AND INSPECTION

1. Upon receipt of equipment and material from Young Industries the following basic steps should be taken:

A. Use the packing list to determine that all the items shipped have been received. Your equipment order was carefully crated or packaged for safe shipment then given to the carrier. Check for damage.

1. Damage in transit is the responsibility of the carrier. Be sure to have the driver sign a copy of the freight bill with a notation above any damage.

2. If a shipment was sent to you by parcel post, have the postmaster complete a damage claim report.

3. Concealed damage: If equipment or goods are discovered to be damaged by shipment at a later date, contact the carrier and Young Industries immediately.

4. IN ALL CASES OF DAMAGE IN TRANSIT, CONTACT THE YOUNG INDUSTRIES ENGINEERING MANAGER AT (570) 546-3165 FOR ASSISTANCE IN DETERMINING WHETHER OR NOT THIS DAMAGE MAY IN ANY WAY AFFECT SAFETY OR PROPER OPERATION OF A DIVERTER VALVE.

5. If shipped UPS, DO NOT THROW ORIGINAL CARTON AWAY. Keep all evidence for the inspector.

NOTE:

YOUNG INDUSTRIES CANNOT ASSUME ANY LIABILITY FOR SHORTAGES OR DAMAGED GOODS. CLAIMS MUST BE NEGOTIATED WITH THE CARRIER. CONTACT THE YOUNG INDUSTRIES AT (570) 546- 3165 FOR ASSISTANCE IN RECTIFYING ANY SHORTAGE OR DAMAGE AS IT RELATES TO SAFE AND PROPER OPERATION OF YOUNG INDUSTRIES EQUIPMENT.

2. Moving the Gravity Diverter Valve

A. Moving and installation should always be performed by trained, experienced personnel, using safe and accepted rigging practices.

CAUTION:

WHEN MOVING A DIVERTER VALVE OR COMPONENT PARTS, BE SURE THAT MOVING PRACTICES USED ARE SAFE FOR BOTH PERSONNEL AND EQUIPMENT. CONTACT THE YOUNG INDUSTRIES ENGINEERING MANAGER IF THERE ARE ANY QUESTIONS RELATING TO WHAT CONSTITUTES SAFE AND ACCEPTED RIGGING PRACTICES FOR MOVEMENT AND/OR INSTALLATION OF A DIVERTER VALVE.

B. Care and caution should be exercised to prevent damaging the valve housing, flanges, piping and auxiliary equipment.

3. Care and caution should be exercised to prevent damaging the valve housing, flanges, piping and auxiliary equipment.

A. If moved to storage, the equipment should be located in a dry area, preferably inside. Outside storage will require adequate protection from the weather.

B. The diverter valve has been shipped with temporary guards or covers for both the inlet and outlet flanges. Do not remove these guards or covers while the equipment is in storage.

C. Refer to the maintenance section of this manual for specific lubrication recommendations prior to beginning any lubrication and/or servicing in preparation for storage. Contact the Young Industries at (570) 546-3165 if you are unsure of any detail or lubrication and/or servicing.

D. After prolonged storage and prior to startup, the equipment shall be inspected by a qualified person. Contact Young Industries at (570) 546-3165 for assistance.

CAUTION:

USE CAUTION TO PROTECT AGAINST OBJECTS OR DEBRIS FROM ENTERING OR DAMAGING THE EQUIPMENT.

B. SUPPORTS

1. Follow the three (3) recommendations listed below and contact Young Industries at (570) 546-3165, if you have any further questions on your particular installation.

A. Gravity diverter valves should be supported by the connecting pipe lines.

B. Connecting flange pipe and supports must be structurally adequate to support an operating valve and be sufficiently rigid to prevent excessive vibration.

C. Connecting flanges must be flat faced and assembled parallel to the valve flange. Care must be exercised to avoid placing excessive stress or bending moments on the valve flanges.

C. ASSEMBLY

1. Before installing the valve and with the power disconnected, check internally for cleanliness, using caution to avoid physical harm to personnel and equipment.

CAUTION:

BEFORE WORKING INTERNALLY ON A VALVE, DISCONNECT POWER. SHUT OFF AND BLEED AIR SYSTEM. USE SPECIAL CARE TO AVOID THE PINCHING ACTION THAT MAY OCCUR BETWEEN THE GATE AND THE VALVE HOUSING.

2. We recommend that the inlet and outlet covers remain in place until the valve is ready to be attached to the mating equipment at both the inlet and outlet openings.

CAUTION:

NEVER OPERATE A GRAVITY DIVERTER VALVE UNLESS THE INLET AND OUTLET OPENINGS ARE COVERED WITH TEMPORARY COVERS OR THE CONNECTING EQUIPMENT.

D. ELECTRICAL INSTALLATION

1. Refer to the IOM manual for the actuator furnished with your gravity diverter valve.

2. Care must be used whenever working on or around the diverter valve as the drive may be remotely controlled.

DANGER:

DISCONNECT POWER, SHUT OFF AND BLEED AIR SUPPLY BEFORE SERVICING

CAUTION:

EXERCISE SAFETY AND STAY CLEAR OF DIVERTER VALVE WHEN TESTING

E. COMPRESSED AIR INSTALLATION

1. When air is required for a valve actuator, the air shall be filtered and moisture free with a pressure of 60 to 110 PSIG.

CAUTION:

COMPRESSED GAS - SHUT OFF AND BLEED SYSTEM BEFORE SERVICING.

F. PRECOMMISSIONING

1. Inspect shaft bearings and gearing for lubrication (see Maintenance Lubrication).

2. Determine that air and power are properly installed and operative.

3. Determine that valve is properly supported.

4. The gravity diverter valve and all product lines must be clean and operational.

5. Check alignment of drive components. Assure that all guards are in position and properly tightened.

6. We urge the installation crew to notify the plant safety committee and/or the plant engineer when installation is complete and prior to initial operation. Those in your plant responsible for plant safety should review your diverter valve installation prior to operation for safety in light of the extensive recommendations made within this manual. Contact Young Industries, telephone

manual. Contact Young Industries, telephone (570) 546- 3165, if this review results in additional questions or uncertainty.

CAUTION:
ROTATING MACHINERY - DO NOT OPERATE WITH GUARD OR COVER REMOVED.

OPERATION

A. STARTUP

1. Prior to actual operation, the operator must familiarize himself with the method of starting and stopping the diverter valve and the status of supporting utilities.

2. The general appearance of the diverter valve and surrounding area should be visually inspected to determine that the valve components can be operated safely and without damage.

CAUTION:
ROTATING MACHINERY - DO NOT OPERATE WITH GUARD OR COVER REMOVED.

3. If your particular installation has an unsafe condition unforeseen by Young Industries and beyond typical operating conditions, CEASE FURTHER OPERATION of the diverter valve and immediately notify both your safety committee and Young Industries at (570) 546-3165. The Young Industries can assist you in speeding the return of your diverter valve installation to a recommended operating condition.

B. CONTINUOUS OPERATION

1. During valve operation the operator should recognize and report any unusual noise or vibration. Bearing and shaft seals should be observed on a regular basis. Look for any excessive bearing temperatures and/ or wear to the shaft seals. Seals may become worn and need to be replaced. Notify your maintenance

personnel or call Young Industries for assistance or additional guidance in defining these conditions. Refer also to the maintenance section of this manual.

2. Guards or covers shall be in place whenever the diverter valve is in service.

CAUTION:
ROTATING MACHINERY - KEEP HANDS CLEAR. DO NOT OPEN WHILE MACHINE IS IN MOTION.

The diverter valve is designed and selected to meet specific operating conditions. Care shall be exercised to assure that the valve is operated within safe limits. The valve should be used only for the purpose for which it is designed. Refer to Young Industries quotation to determine the application for which this diverter valve was intended. Contact the Sales Manager at Young Industries, Painter Street, Muncy, PA 17756, if you need assistance in determining the proper application of your Young Industries gravity diverter valve.

C. SHUTDOWN

1. When shutting down a diverter valve, shut off supporting utilities in accordance with plant operating procedures.

2. When cleaning or servicing is required on the valve, proper lock-out of electrical, compressed gas and mechanical equipment should be completed before the work is started.

MAINTENANCE

A. LUBRICATION

1. During the first few months of operation, the lubrication of the bearings and drive should be observed frequently to assure proper operation.

2. After the initial operating period, we recommend that your plant engineering and maintenance personnel continue preventive maintenance and lubrication on a regular schedule. Contact Young Industries at (570) 546-3165, if you need additional assistance to set up an on-going lubrication and preventative maintenance schedule.

DANGER:
DISCONNECT POWER. SHUT OFF COMPRESSED AIR AND BLEED SYSTEM BEFORE SERVICING.

3. Lubricate the valve bearings with NGLI 2 lithium soap grease with petroleum oil or compatible grease

CAUTION:
ROTATING MACHINERY - DO NOT OPERATE WITH GUARDS OR COVER REMOVED.

4. Equipment that is out of service for extended periods of time (30 days or longer) or equipment that is placed in storage (inside or outside) should have all unpainted carbon steel surfaces coated with a rust preventative (Gulf No-Rust C or equivalent).

B. DRIVE

1. Valve actuator should be inspected for proper operation in accordance with actuator IOM manual.

2. Check utilities for valve actuator and control.

CAUTION:
DISCONNECT POWER, SHUT OFF AND BLEED AIR SUPPLY BEFORE SERVICING.

C. BEARINGS AND SEALS

1. Bearings

A. Diverter valve bearings should be routinely checked for proper lubrication. Excessive heat, vibration or unusual noise may indicate a potential bearing problem.

2. Seals

A. Visually inspect the shaft seals for leaks. If shaft seal is leaking, replace shaft o-ring seal.

D. GENERAL INSPECTION

1. Observe valve when operating for any unusual vibration or noise.

2. Check inlet and outlet pipe connections for tightness.

3. Check valve support.

4. Check compressed air piping (when applicable) and associated valves and guards.

DANGER:
DISCONNECT POWER, SHUT AND BLEED AIR SUPPLY BEFORE SERVICING.

CAUTION:
EXERCISE SAFETY AND STAY CLEAR OF DIVERTER VALVE WHEN TESTING.

E. TROUBLESHOOTING

1. When properly installed, operated and maintained, your Young Industries gravity diverter valve will give years of service. Table One, "Troubleshooting Gravity Diverter Valves," gives symptoms, causes and remedies for most problems that may be encountered.

SPARE PARTS

1. A nameplate is furnished with each diverter valve. The necessary information for ordering spare parts is found on this nameplate. When ordering, please provide (a) SHOP NUMBER and (b) SERIAL NUMBER. Contact the Spare Parts Manager at (570) 546-3165 for assistance.

TABLE 1 - TROUBLE SHOOTING GRAVITY DIVERTER VALVES

TABLE 1 - TROUBLE SHOOTING GRAVITY DIVERTER VALVES

<u>SYMPTOM</u>	<u>CAUSE</u>	<u>REMEDY</u>
Valve will not move.	Lack of air supply.	Have air source checked; turn on air supply. Check air pressure.
	Electrical power source not furnishing power.	Have power source checked; turn on power.
	Solenoid burned out.	Replace Solenoid.
	Actuator control valve not operating.	Replace or repair control valve.
	Valve gate jammed.	Remove cause of jamming; possible product of foreign object.
Drive noisy.	Drive out of alignment.	Align and tighten.
	Foreign object in drive.	Remove foreign object.
Valve Noisy.	Gate rubbing on housing.	Align and reposition gate in housing. Replace worn bearing
	Product build-up on housing or swing gate.	Remove product build-up.
Excessive leakage between inlet and outlet valve ports.	Worn flexible tip.	Replace flexible tip.
Shaft Seals leaking.	Worn or damaged shaft O-ring seal.	Replace O-ring.
Bearing noisy or overheated.	No lubrication.	Lubricate bearing.
	Worn bearing.	Replace bearing.
	Bearing failure.	Replace bearing.

CAUTION:

DO NOT OPERATE WITH GUARDS OR COVER REMOVED.

CAUTION:

DO NOT EXTEND HANDS OR HAND-HELD OBJECTS INTO DIVERTER VALVE.

CAUTION:

DISCONNECT AND LOCK OUT POWER BEFORE SERVICING.

CAUTION:

COMPRESSED GAS – LOCK OUT AND BLEED SYSTEM BEFORE SERVICING.

FIGURE 1 - TDV EXPLODED VIEW

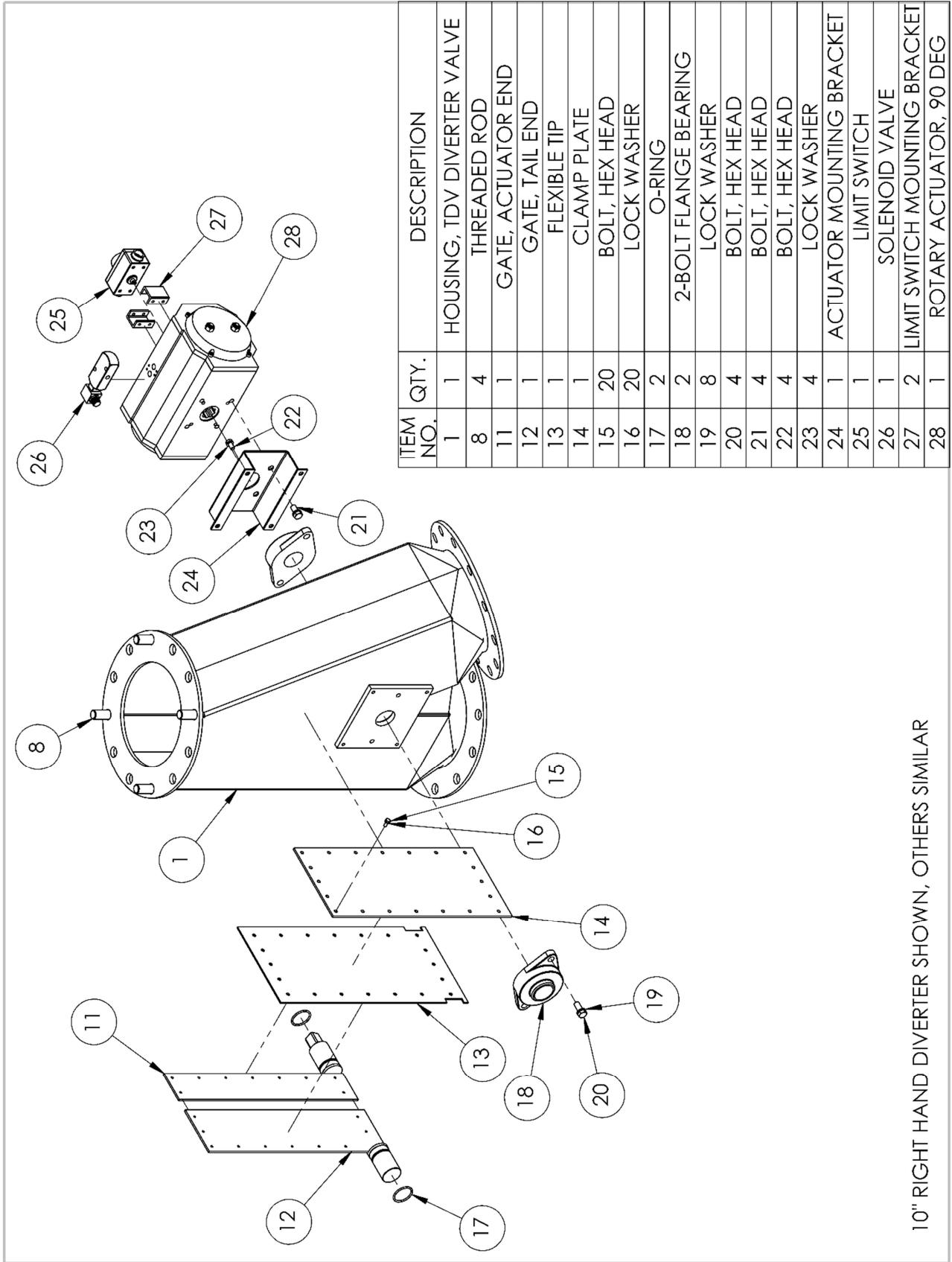

10" RIGHT HAND DIVERTER SHOWN, OTHERS SIMILAR

FIGURE 2 - BUCKET DIVERTER VALVE EXPLODED VIEW

FIGURE 2 - BDV EXPLODED VIEW

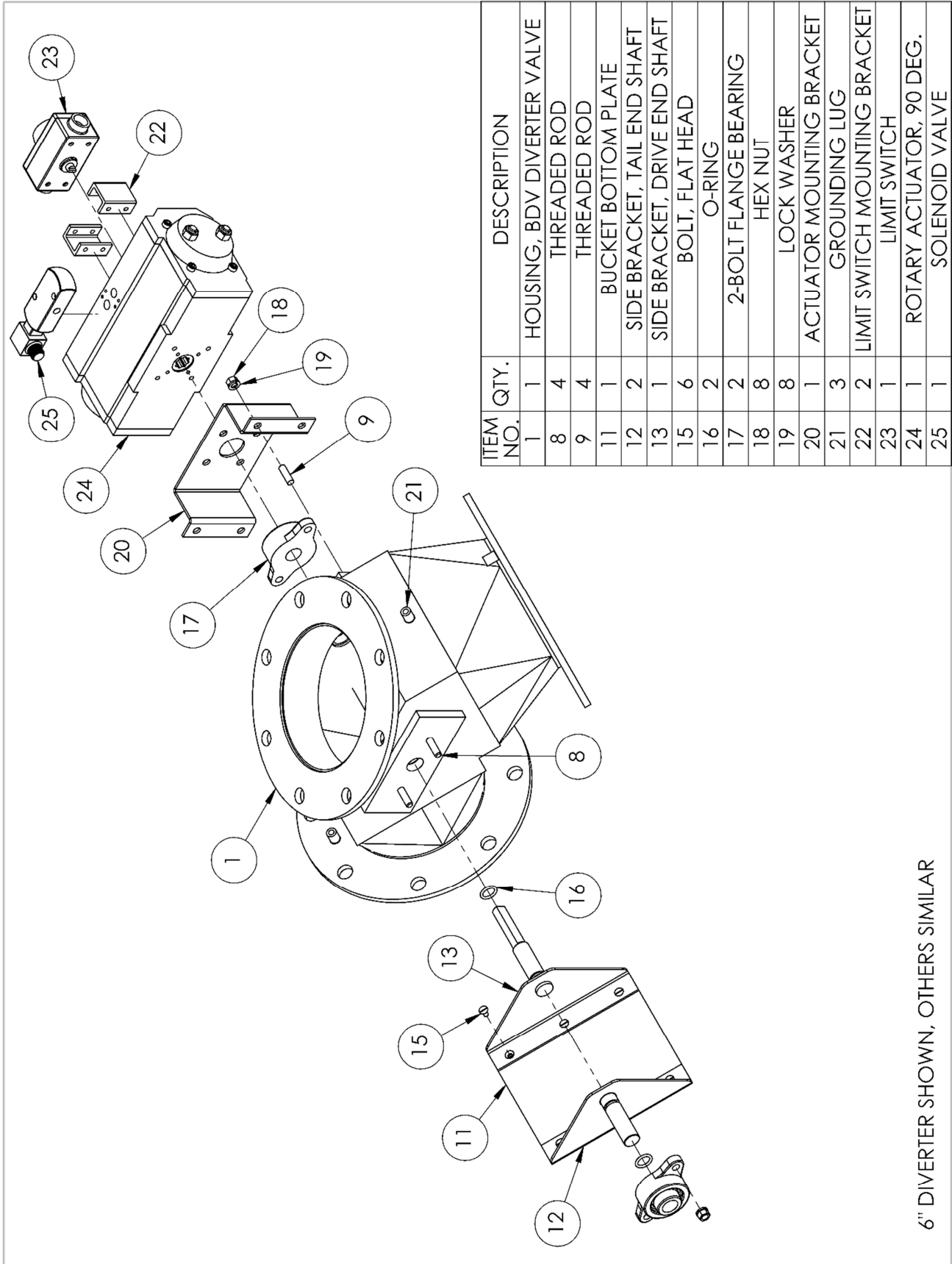

6" DIVERTER SHOWN, OTHERS SIMILAR

FIGURE 3 - VT EXPLODED VIEW

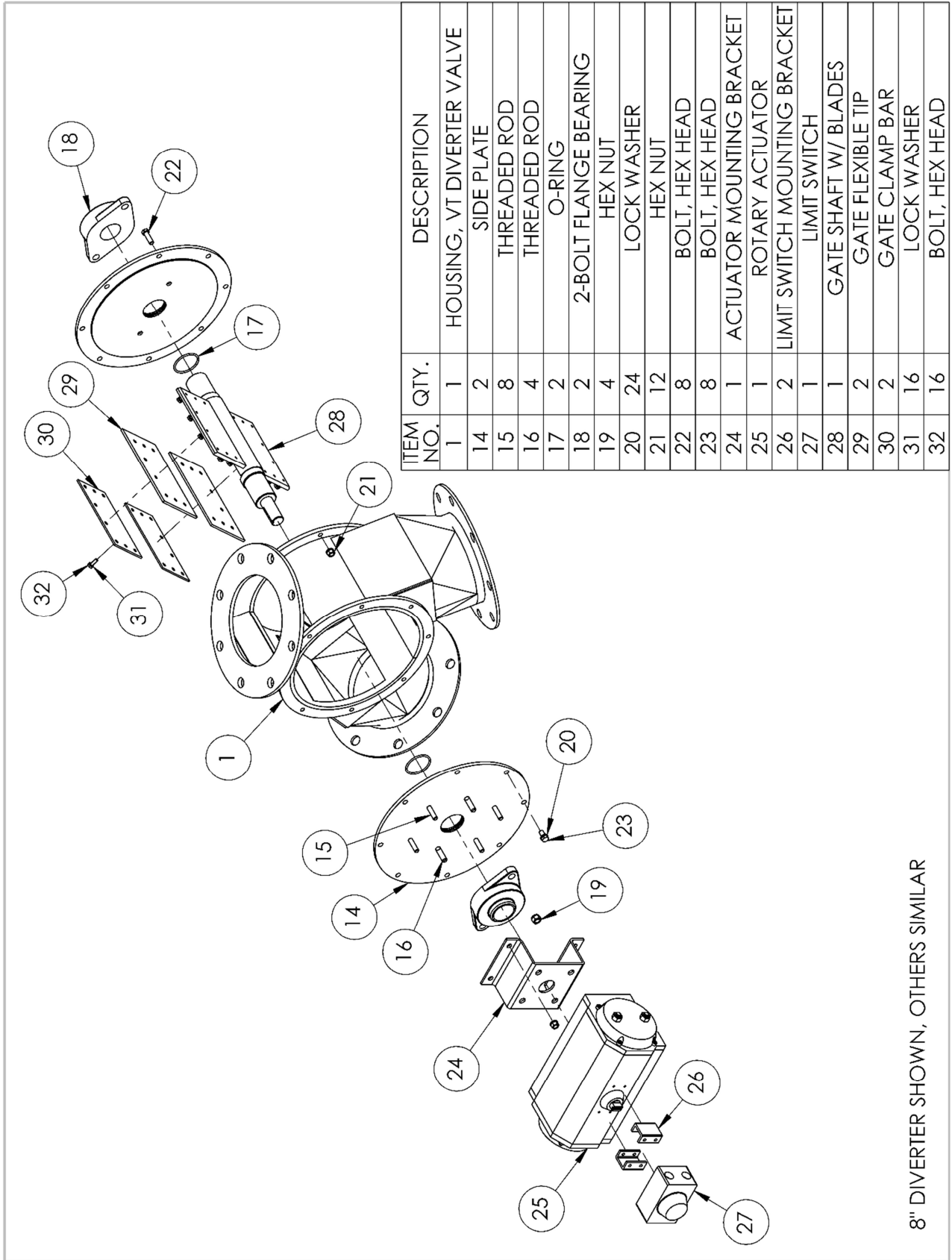

8" DIVERTER SHOWN, OTHERS SIMILAR

FIGURE 4 - ROTARY VANE DIVERTER VALVE (SHROUDED GATE) EXPLODED VIEW

FIGURE 4 - VT (SHROUDED GATE) EXPLODED VIEW

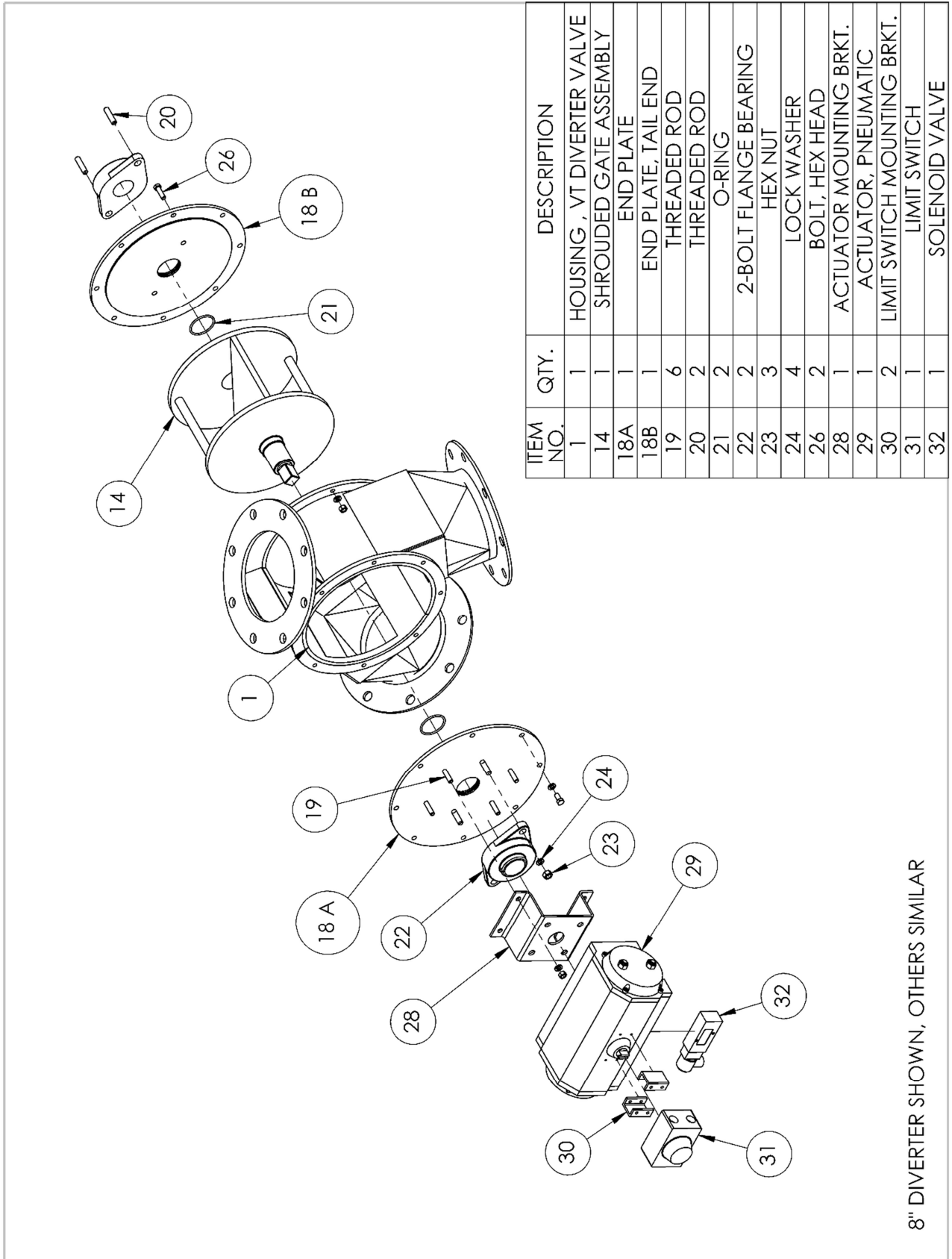

THE YOUNG
 INDUSTRIES, INC.
 Muncy, Pennsylvania 17756
 TELEPHONE: 570-546-3165

MADE BY	KFH	DATE	7/24/93	ORDER NO.		ISSUE	
CHKD	PFEIFFER		7/26/93				
APPR	PFEIFFER		7/26/93	SHEET	1	OF	1
CUST.	-						
TITLE	GROUNDING/BONDING WARNING						

WARNING – ELECTRICAL GROUNDING AND BONDING ARE REQUIRED

Ungrounded machinery presents a potential hazard of fatal electrical shock from electrical power sources. Static electricity may also accumulate on ungrounded/unbonded equipment. Static electricity discharge from ungrounded equipment or between unbonded pieces of equipment may cause explosion or fire if flammable vapor or dust is present.

Electrical equipment must be installed by a certified professional electrician.

Before operating the equipment described by this manual or any other equipment in the same processing system, grounding and bonding must be completed in accordance with the National Electrical Code (NFPA 70) published by the National Fire Protection Association, 1 Batterymarch Park, Quincy, Mass. 02269-9101, and any other applicable National, State or Municipal codes. Codes for safe control of static electricity must also be observed, including the National Fire Code “Recommended Practice on Static Electricity” (NFPA 77) and any other applicable National, State or Municipal codes.

To avoid hazardous static discharge, mobile, movable or portable equipment which may attach to or come near to other equipment and which is not prohibited by codes from being connected to ground must be safely grounded and bonded before close approach or contact is made. This warning also applies to movable containers such as drums, totes, boxes and bags.

Sections of pipe, duct and gravity spout must be bonded to adjacent sections and must have a conductive path to electrical ground.

Regular periodic safety inspections of electrical systems and grounding/bonding systems are required.

LOOK FOR THESE TAGS AND TERMINAL CONNECTING POINTS

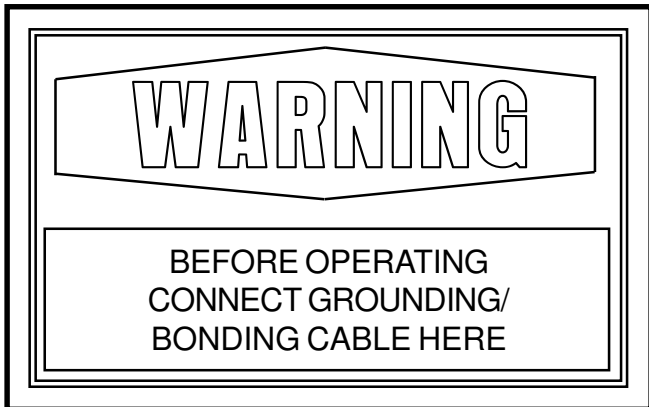

CABLES AND TERMINATIONS MUST BE SUPPLIED BY INSTALLER

