

- NOTES:
1. VALVE HOUSINGS ARE CAST OF IRON OR ALUMINUM; FABRICATED OF STEEL OR STAINLESS STEEL. ALL ROTORS ARE FABRICATED OF STEEL OR STAINLESS STEEL.
 2. VALVE HOUSINGS ARE AVAILABLE WITH ANY COMBINATION OF SQUARE OR ROUND INLET AND OUTLET. ROUND FLANGES MATCH 150# ANSI DRILLING.
 3. STANDARD HOUSINGS ARE DESIGNED FOR 15 PSI (MAX) INTERNAL & DIFFERENTIAL @ 250 DEGREES F.
 4. END PLATE O-RINGS ARE OPTIONAL AND WILL BE FURNISHED ONLY WHEN SPECIFIED.
 5. AIR PURGE CONNECTIONS 1/8" NPT WITH BRASS LANTERN RINGS ARE OPTIONAL AND WILL BE FURNISHED ONLY WHEN SPECIFIED.
 6. VENT WITH SCH 10 PIPE IS OPTIONAL AND WILL BE FURNISHED ONLY WHEN SPECIFIED. VENT CONNECTION WILL CHANGE ROTOR ROTATION TO COUNTER-CLOCKWISE.

TOTALLY ENCLOSED OSHA DESIGN CHAIN GUARD
 TOTALLY ENCLOSED CHAIN DRIVE INCLUDES:
 DRIVE SPROCKET
 VALVE SPROCKET
 ROLLER CHAIN

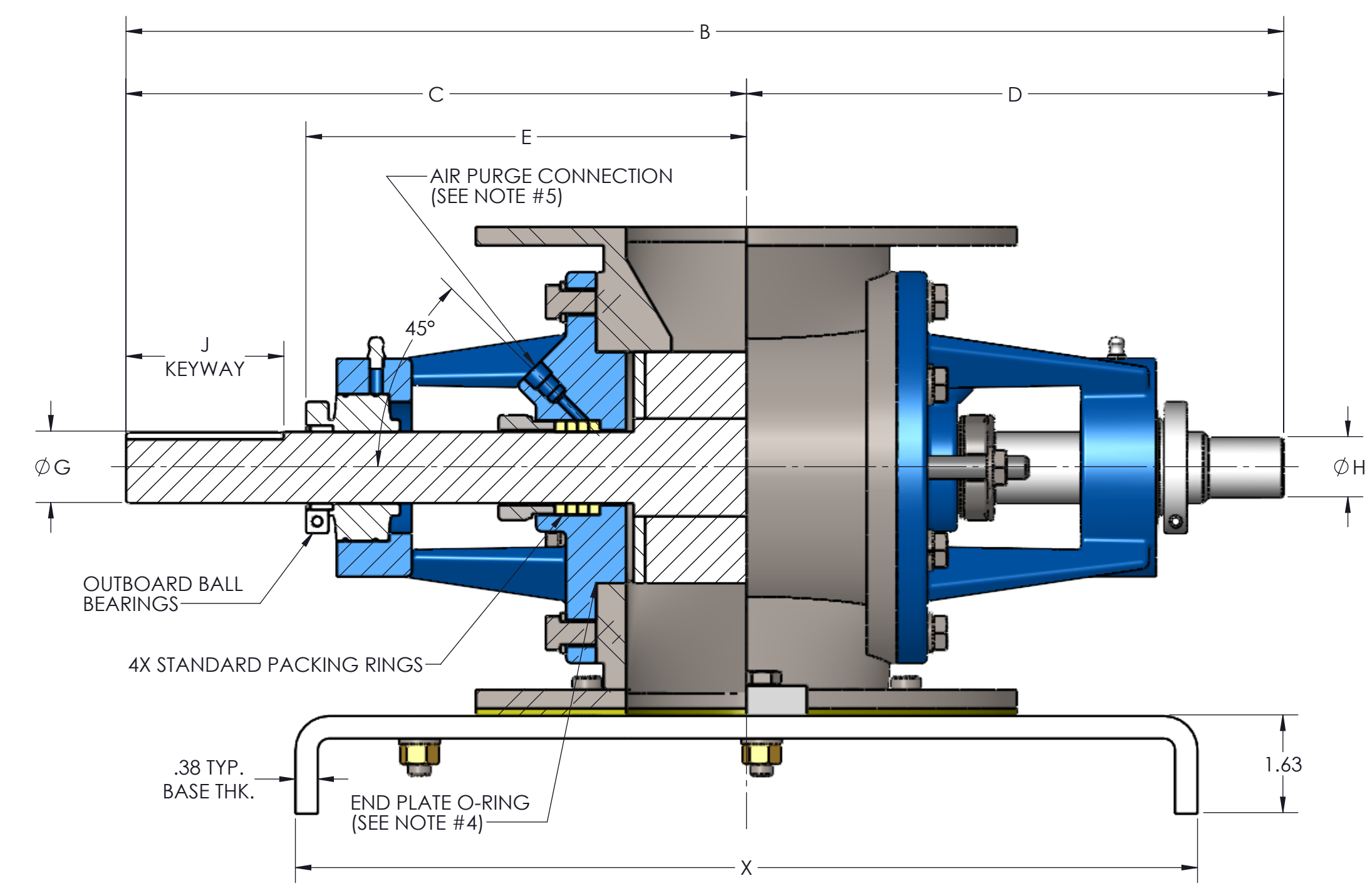
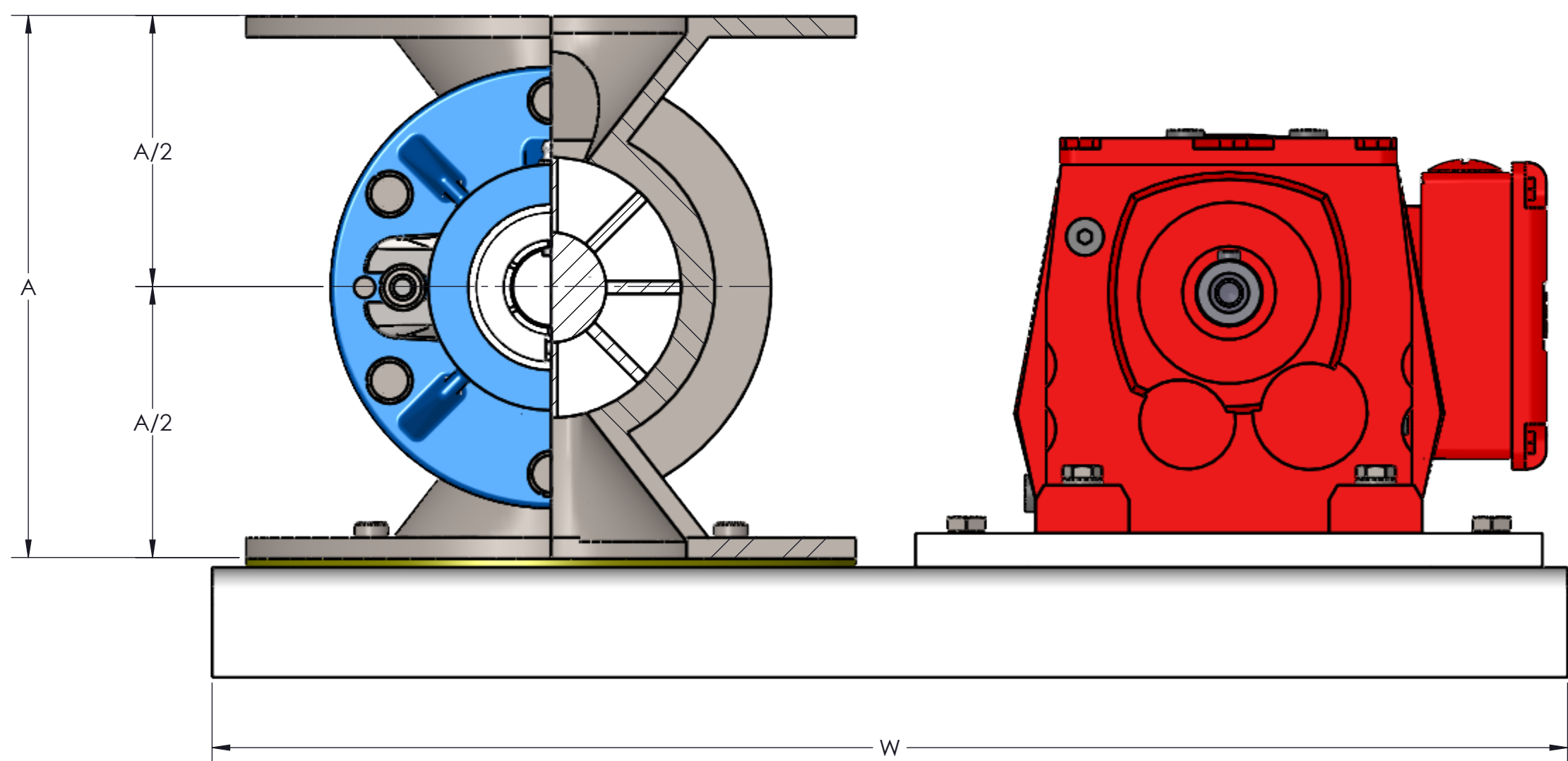
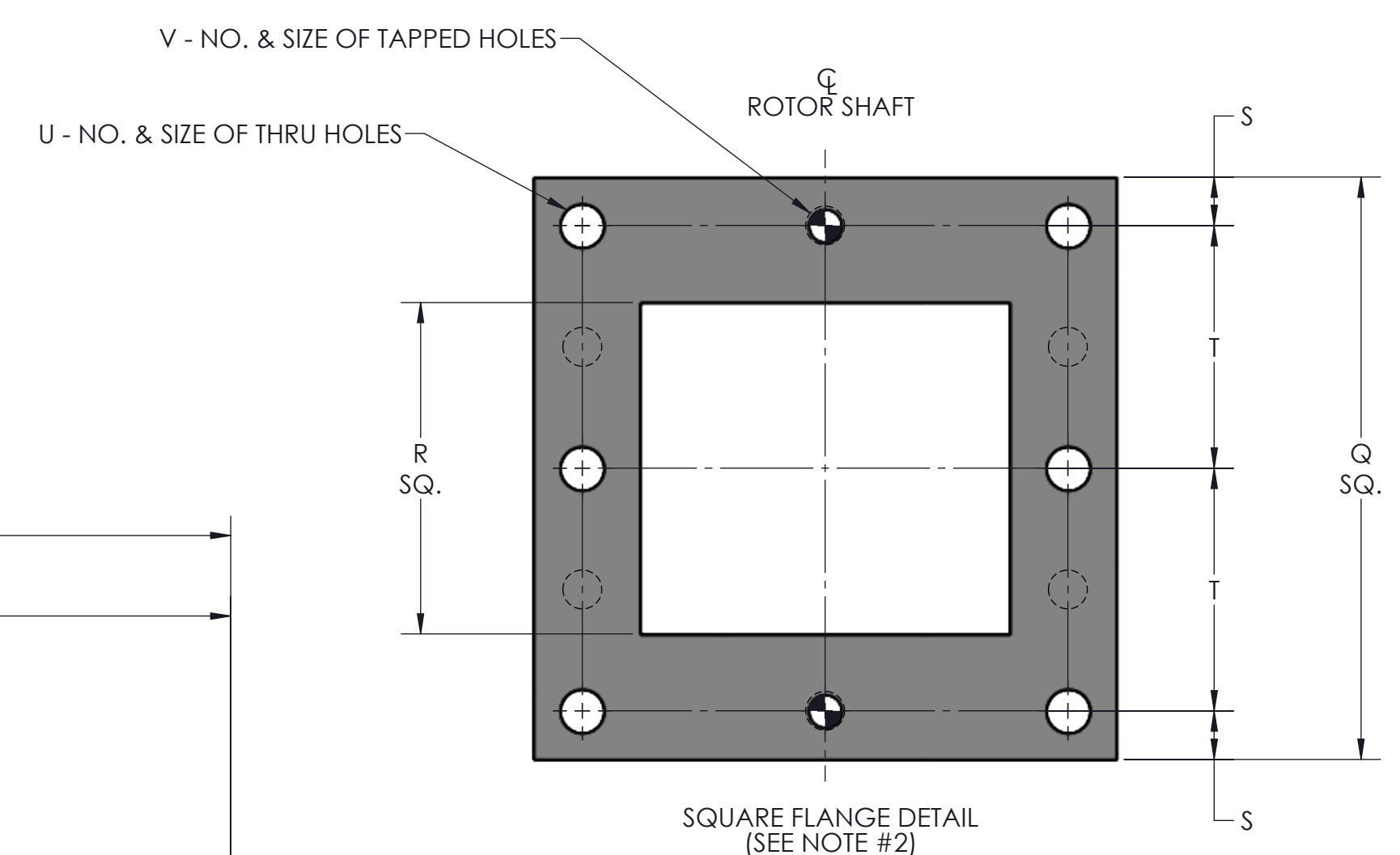

ROTOR DIA. X LG.	ROTOR CAP. (CU. FT. PER REV.)			STD RPM	VENT SIZE	STD HP	A	B	C	D	E	F	G	H	J	K	L	M	N	P	Q	R	S	T	U	V	W	X	WEIGHT C/S
	AS	BS	CS																										
4 X 4	.0169	.011	.00741	38	1.25	.50	8.00	19.25	10.31	8.94	7.31	.31	1.19	1.00	.25 X .12 X 2.62	9.00	7.50	4.00	(4) .75	(4) .62-11UNC-2B	7.50	4.00	.62	3.12	(6) .56	(2) .50-13UNC-2B	20.00	15.00	205
5 X 5	.0362	.0235	.0117	38	1.50	.50	9.00	20.25	10.81	9.44	7.81	.44	1.19	1.00	.25 X .12 X 2.62	10.00	8.50	5.00	(4) .88	(4) .75-10UNC-2B	8.50	5.00	.62	3.62	(6) .56	(2) .50-13UNC-2B	20.50	15.50	220

GENERAL TOLERANCES
 UNLESS OTHERWISE SPECIFIED THE FOLLOWING SHALL APPLY
 MACHINING - XX=.02 XXX=.005 ANGLE=30°
 SURFACE ROUGHNESS HEIGHT 63 MICRONS OR LESS
 FABRICATION - UNDER 6 6 TO 24 24 TO 60 OVER 60
 ±.06 ±.12 ±.19 ±.25
 UNLESS OTHERWISE SPECIFIED DIMENSIONS ARE IN INCHES.
 UNLESS SPECIFIED DIMENSIONS & TOLERANCES INTERPRETED PER ASME Y14.5-2009

REV. NO.	DESCRIPTION	DATE	BY
REVISIONS			
CUSTOMER:			
CUSTOMER PO NUMBER:			
YOUNG JOB NUMBER:			
TITLE			
YOUNG INDUSTRIES MODEL 'LH' ROTARY VALVE, SIZE 4"-5", CLASS 15 W/ PARALLEL SHAFT DRIVE, CLOSED ROTOR STANDARD DIMENSION SHEET			
DRAWN BY: MEA		DATE: 07/30/24	
CHECKED BY:		SCALE: 1:2	
DRAWING NUMBER: D-21404-17		SHEET 1 OF 1	REV: 00