

ROTOR SIZES 6" - 16" 8 VANES  
18" - 24" 12 VANES

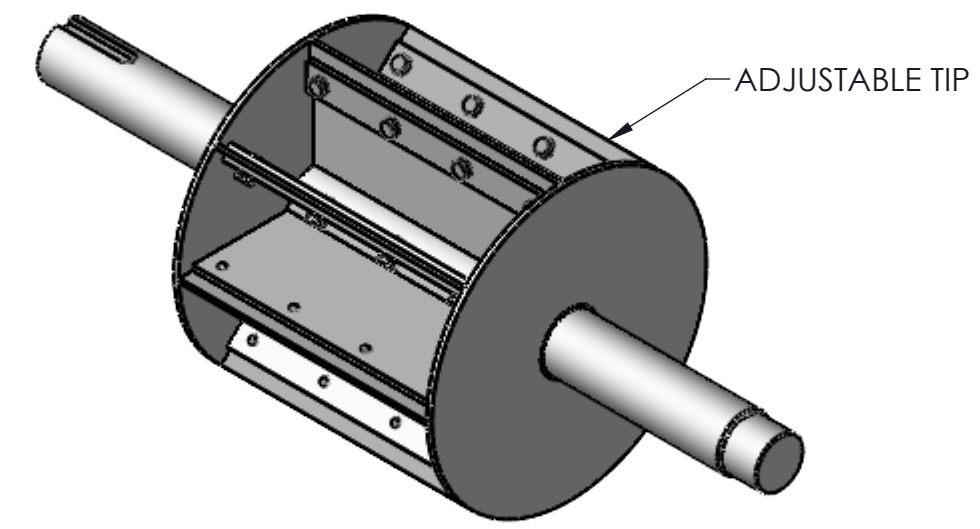

TOTALLY ENCLOSED OSHA DESIGNED CHAIN GUARD  
TOTALLY ENCLOSED CHAIN DRIVE INCLUDES:  
VALVE SPROCKET  
DRIVE SPROCKET  
ROLLER CHAIN

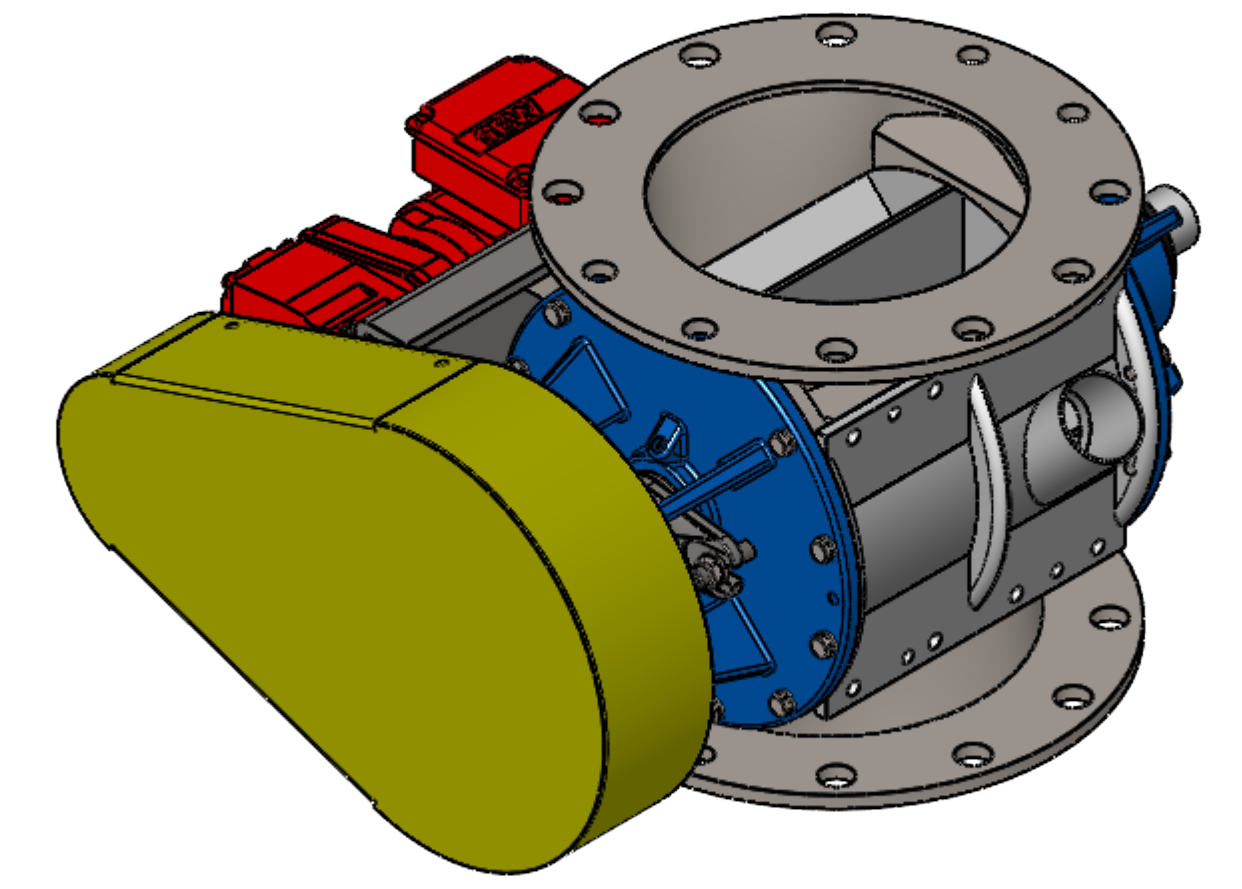
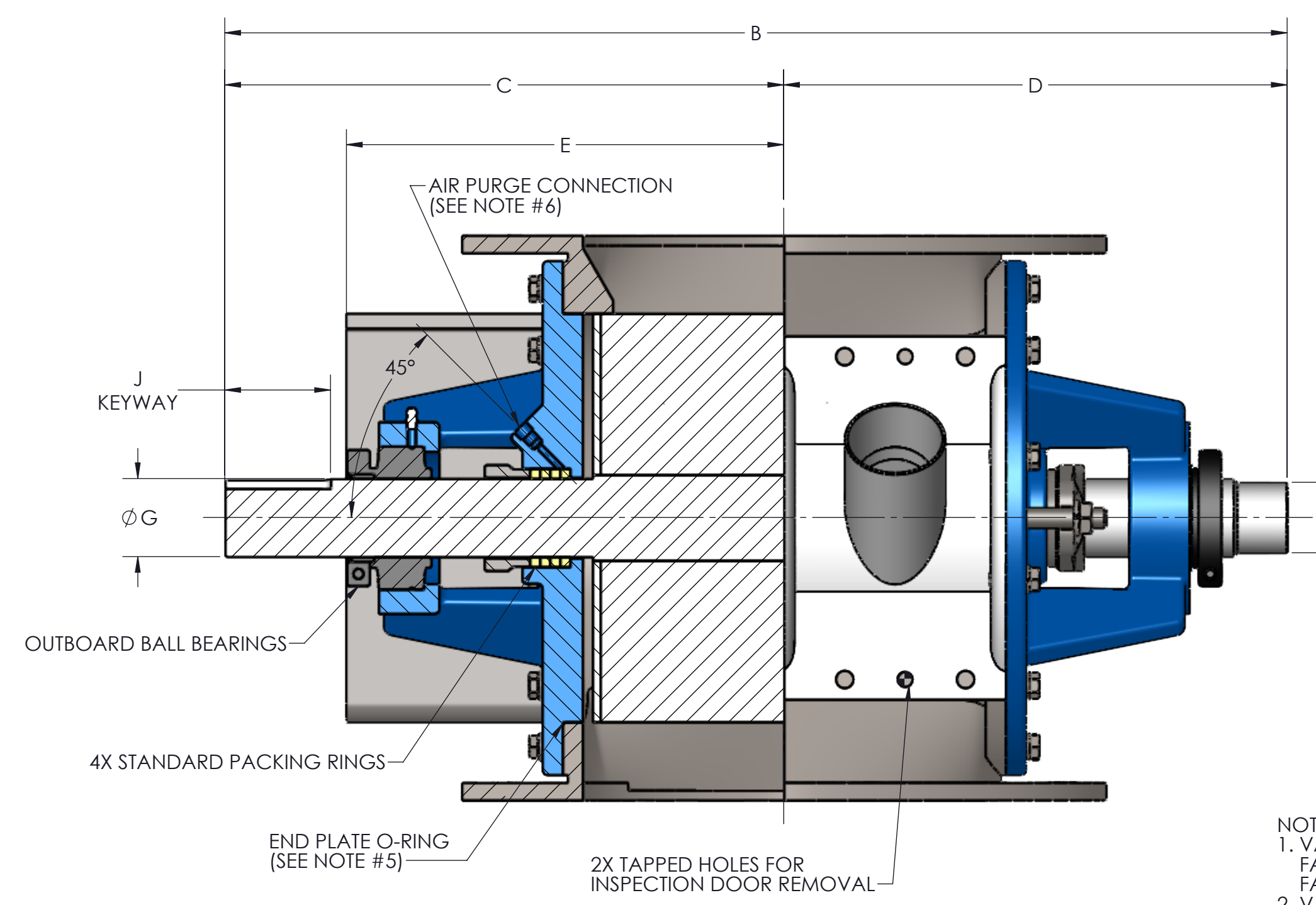
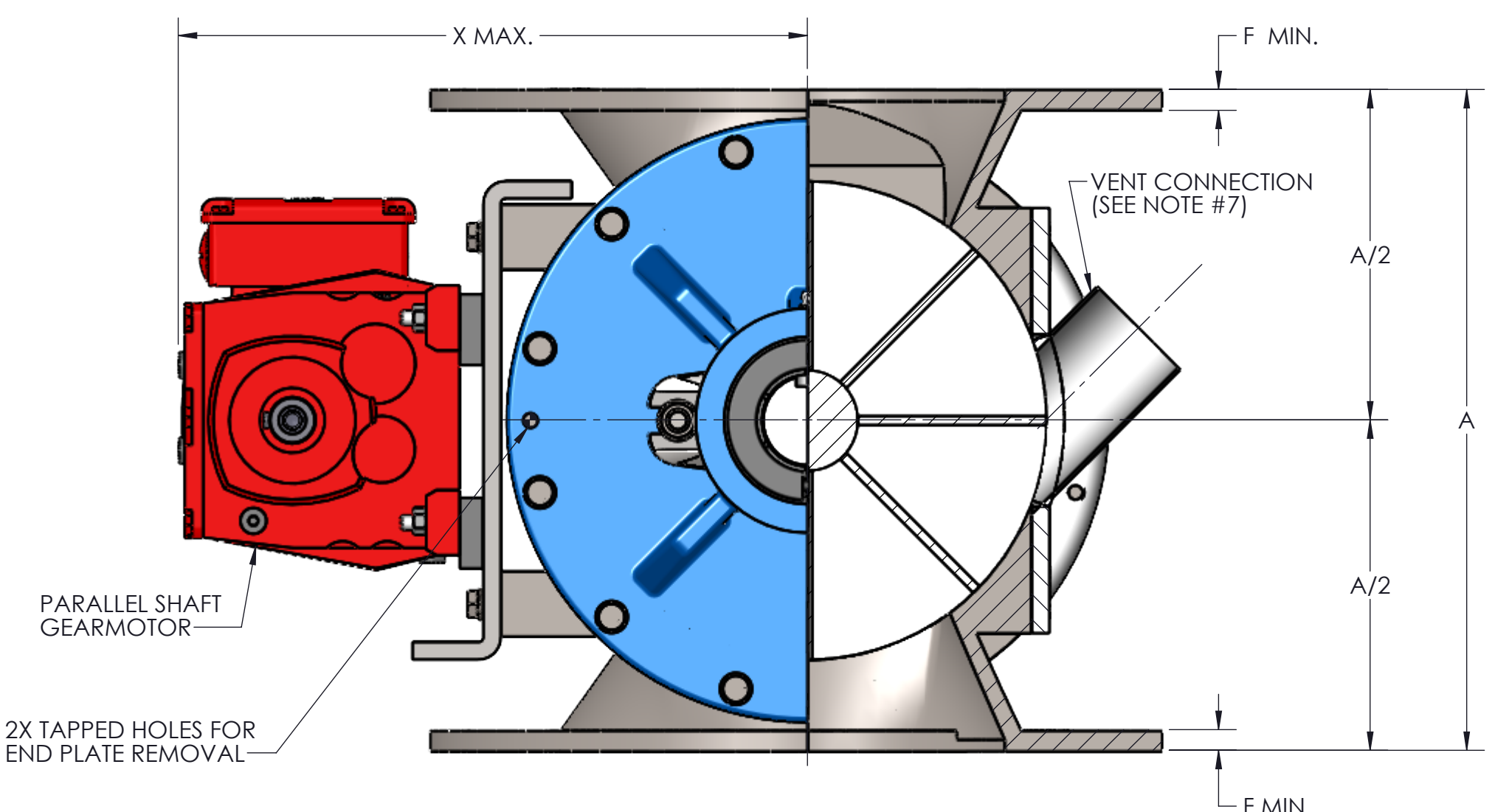

SIZE	ROTOR DIA. X LG.	ROTOR CAPACITY (CU. FT. PER REV)				STD RPM	VENT SIZE	STD HP	A	B	C	D	E	F	G	H	J	K	L	M	N	P	Q	R	S	T	U	V	W	X	WEIGHT (C/S)
		AS	BS	CS	DS																										
6	6 X 6	.0709	.0453	.0214	.0655	32	1.50	.50	10.00	21.25	11.31	9.94	8.31	.44	1.19	1.00	.25 X .12 X 2.62	11.00	9.50	6.00	(4) .88	(4) .75-10UNC-2B	9.50	6.00	.62	4.12	N/A	(6) .56	(2) .50-13UNC-2B	13.31	245
8	8 X 8	.182	.112	.0765	.175	32	2.00	.50	12.00	23.50	12.44	11.06	9.44	.44	1.44	1.25	.38 X .19 X 2.62	13.50	11.75	8.00	(4) .88	(4) .75-10UNC-2B	11.50	8.00	.62	5.12	2.56	(14) .56	(2) .50-13UNC-2B	14.31	350
10	10 X 10	.371	.221	.142	.361	32	2.50	.50	14.00	26.38	13.88	12.50	10.88	.44	1.94	1.75	.50 X .25 X 2.62	16.00	14.25	10.00	(8) 1.00	(4) .88-9UNC-2B	14.75	10.00	1.00	6.38	3.19	(14) .56	(2) .50-13UNC-2B	15.38	415
12	12 X 12	.627	.341	.184	.620	32	2.50	.75	17.00	28.38	14.88	13.50	11.88	.56	1.94	1.75	.50 X .25 X 2.62	19.00	17.00	12.00	(8) 1.00	(4) .88-9UNC-2B	16.75	12.00	1.00	7.38	3.69	(14) .56	(2) .50-13UNC-2B	16.38	580
14	15 X 13	1.096	.682	.208	1.089	30	3.00	.75	20.00	29.62	15.38	14.25	12.38	.56	2.19	2.00	.50 X .25 X 2.62	21.00	18.75	13.00	(8) 1.12	(4) 1.00-8UNC-2B	18.00	13.00	1.00	8.00	4.00	(14) .56	(2) .50-13UNC-2B	18.00	750
16	17 X 15	1.664	.857	.332	1.656	30	3.50	1.0	22.00	32.75	17.31	15.44	13.56	.62	2.44	2.25	.62 X .31 X 3.38	23.50	21.25	15.00	(12) 1.12	(4) 1.00-8UNC-2B	20.00	15.00	1.00	9.00	4.50	(14) .69	(2) .62-11UNC-2B	19.00	900
18	19 X 17	2.327	1.239	.602	2.313	28	3.50	1.0	24.00	34.75	18.31	16.44	14.56	.62	2.44	2.25	.62 X .31 X 3.38	25.00	22.75	17.00	(12) 1.25	(4) 1.12-7UNC-2B	22.00	17.00	1.00	10.00	5.00	(14) .69	(2) .62-11UNC-2B	19.94	950
20	21 X 19	2.982	1.594	.777	2.978	28	4.00	1.5	26.00	38.62	20.31	18.31	16.44	.62	2.94	2.75	.75 X .38 X 3.50	27.50	25.00	19.00	(16) 1.25	(4) 1.12-7UNC-2B	25.50	19.00	1.25	11.50	5.75	(14) .81	(2) .75-10UNC-2B	22.00	1450
22	23 X 21	4.042	2.201	.978	4.037	26	5.00	1.5	28.00	40.62	21.31	19.31	17.44	.62	2.94	2.75	.75 X .38 X 3.50	29.75	27.25	21.00	(16) 1.38	(4) 1.25-7UNC-2B	27.50	21.00	1.25	12.50	6.25	(14) .81	(2) .75-10UNC-2B	23.00	1520
24	25 X 23	5.314	2.869	1.305	5.308	24	5.00	1.5	30.00	42.62	22.31	20.31	18.44	.62	2.94	2.75	.75 X .38 X 3.50	32.00	29.50	23.00	(16) 1.38	(4) 1.25-7UNC-2B	29.50	23.00	1.25	13.50	6.75	(14) .81	(2) .75-10UNC-2B	24.06	1600

- NOTES:
1. VALVE HOUSINGS ARE CAST OF IRON OR ALUMINUM; FABRICATED OF STEEL OR STAINLESS STEEL. ALL ROTORS ARE FABRICATED OF STEEL OR STAINLESS STEEL.
  2. VALVE HOUSINGS ARE AVAILABLE WITH ANY COMBINATION OF SQUARE OR ROUND INLET AND OUTLET. ROUND FLANGES MATCH 150# ANSI DRILLING.
  3. STANDARD HOUSINGS ARE DESIGNED FOR 15 PSI (MAX) INTERNAL & DIFFERENTIAL @ 250 DEGREES F.
  4. INSPECTION DOOR IS OPTIONAL AND WILL BE FURNISHED ONLY WHEN SPECIFIED.
  5. END PLATES AND INSPECTION DOOR O-RINGS ARE OPTIONAL AND WILL BE FURNISHED ONLY WHEN SPECIFIED.
  6. AIR PURGE CONNECTIONS 1/8" NPT WITH BRASS LANTERN RINGS ARE OPTIONAL AND WILL BE FURNISHED ONLY WHEN SPECIFIED.
  7. VENT WITH SCH 10 PIPE IS OPTIONAL AND WILL BE FURNISHED ONLY WHEN SPECIFIED. VENT CONNECTION WILL CHANGE ROTOR ROTATION TO COUNTER-CLOCKWISE.

GENERAL TOLERANCES UNLESS OTHERWISE SPECIFIED THE FOLLOWING SHALL APPLY	
MACHINING - XX- .02 XXX- .005 ANGLES - 30°	SURFACE ROUGHNESS HEIGHT 63 MICRONS OR LESS
FABRICATION - UNDER 6 6 TO 24 24 TO 60 OVER 60	± .06 ± .12 ± .19 ± .25
UNLESS OTHERWISE SPECIFIED DIMENSIONS ARE IN INCHES. UNLESS SPECIFIED DIMENSIONS & TOLERANCES INTERPRETED PER ASME Y14.5-2009	

REV. NO.	DESCRIPTION	DATE	BY
REVISIONS			
CUSTOMER:			
CUSTOMER PO NUMBER:			
YOUNG JOB NUMBER:			
TITLE			
YOUNG INDUSTRIES MODEL 'LH' ROTARY VALVE, SIZE 6"-24", CLASS 15 W/ PARALLEL SHAFT DRIVE, CLOSED ROTOR STANDARD DIMENSION SHEET			
DRAWN BY: MEA		DATE: 07/25/24	
CHECKED BY:		SCALE: 1:3	
DRAWING NUMBER		SHEET	
D-21404-15		1 OF 1	
REV:		00	

