

ROUND INLET & OUTLET FLANGE DETAIL
SIZES 4" THRU 8" ONLY
150 # ANSI DRILLING

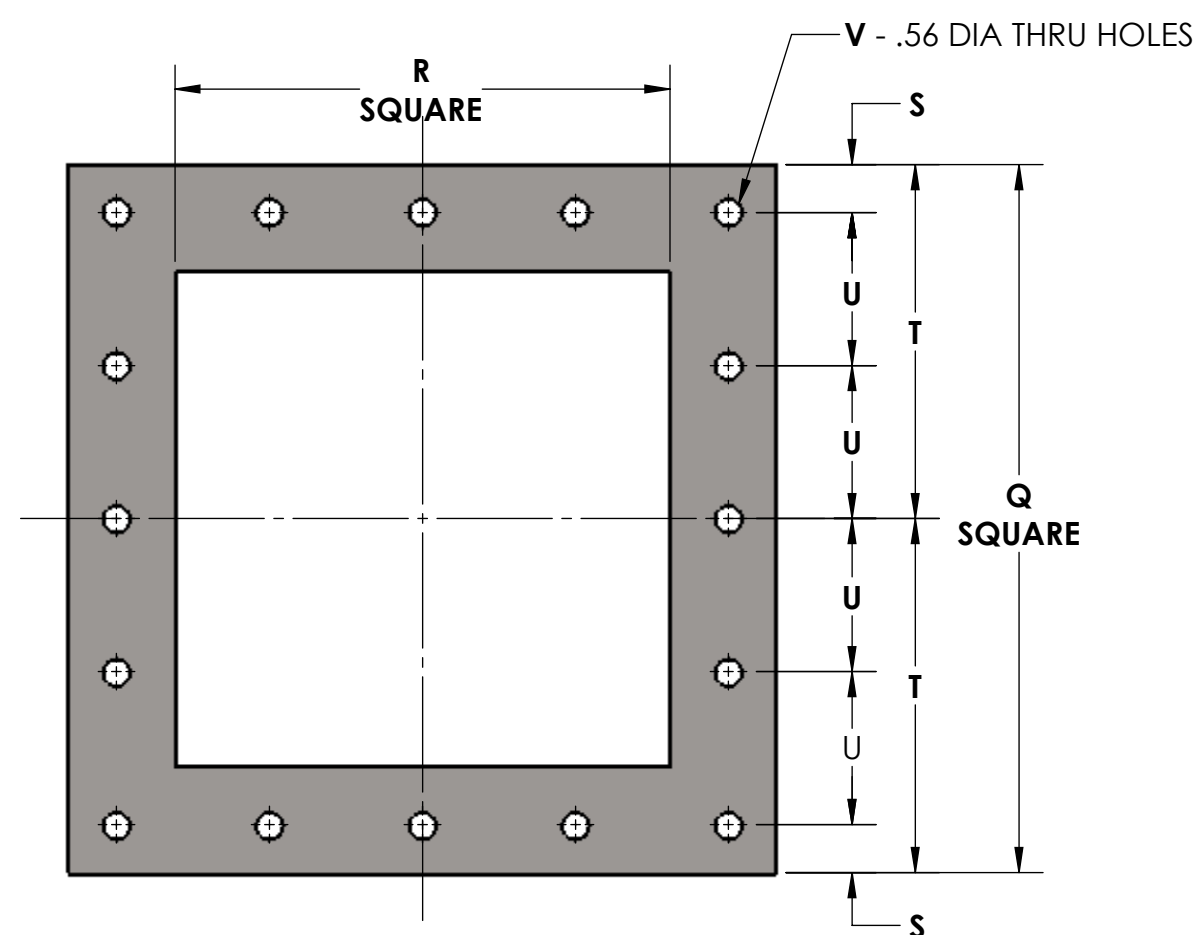

SQUARE INLET & OUTLET FLANGE DETAIL

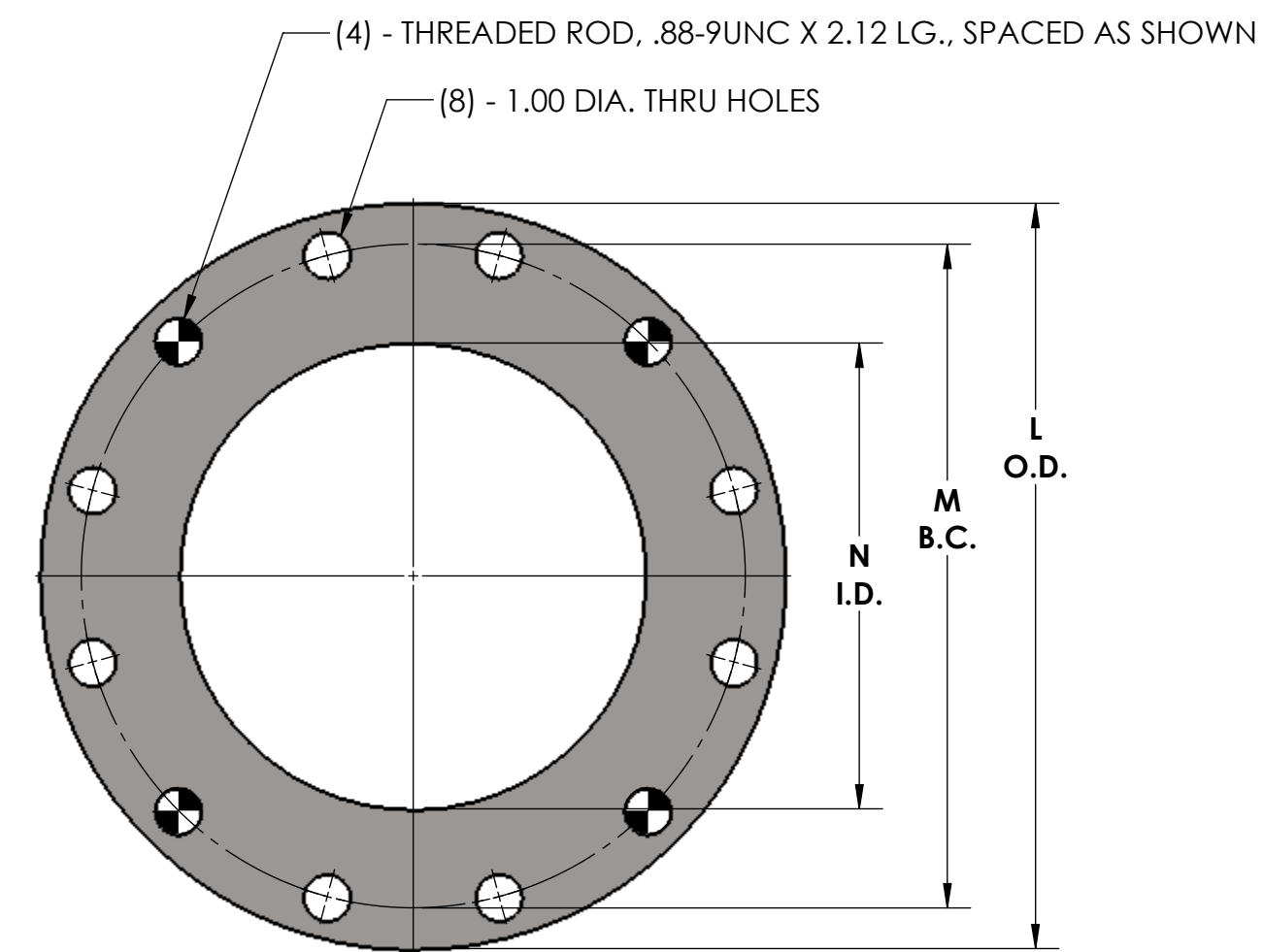

ROUND INLET FLANGE DETAIL
SIZES 10" & 12" ONLY
150 # ANSI DRILLING

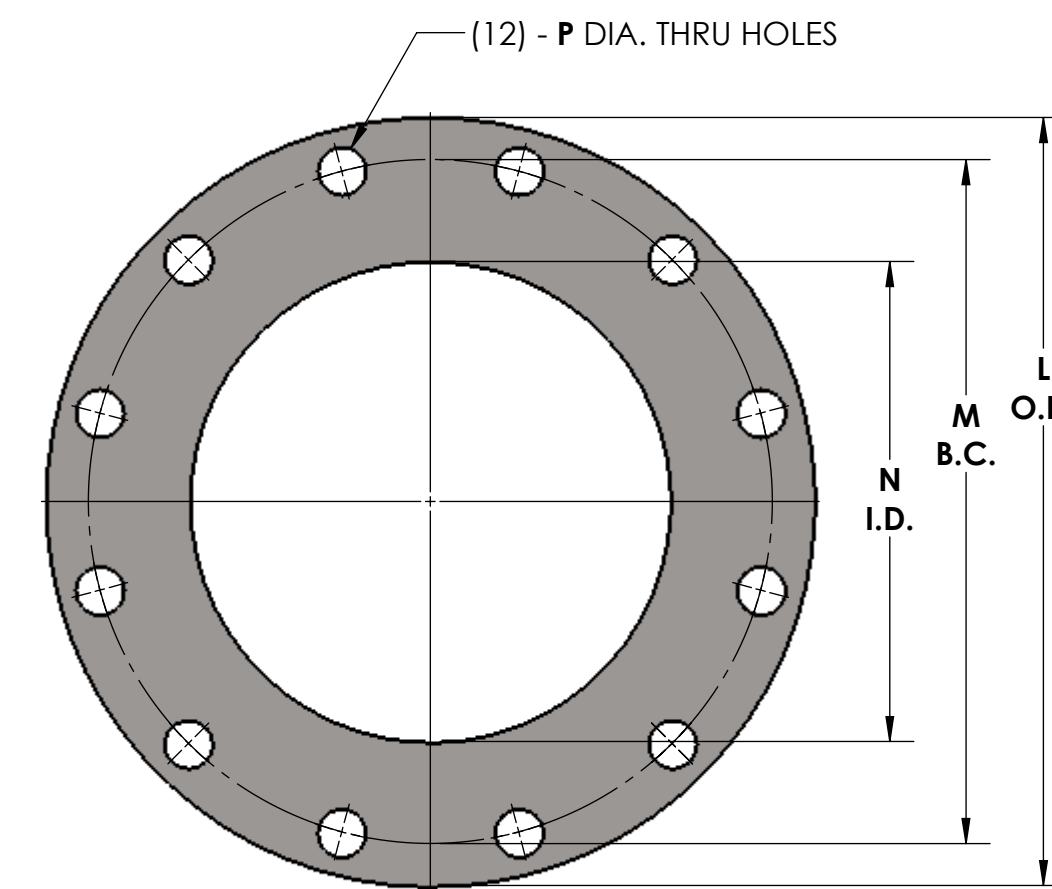

ROUND OUTLET FLANGE DETAIL
SIZES 10" & 12" ONLY
150 # ANSI DRILLING

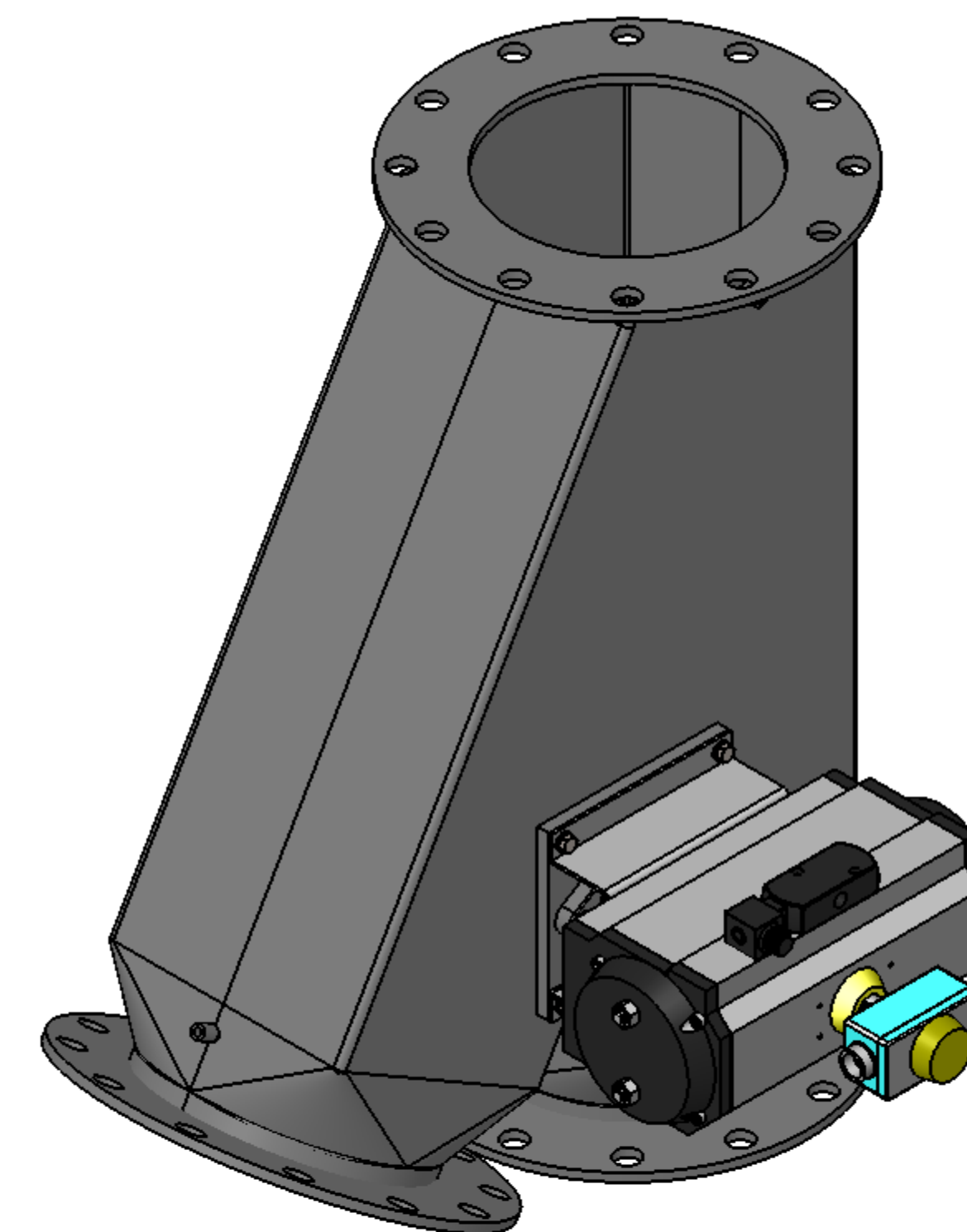
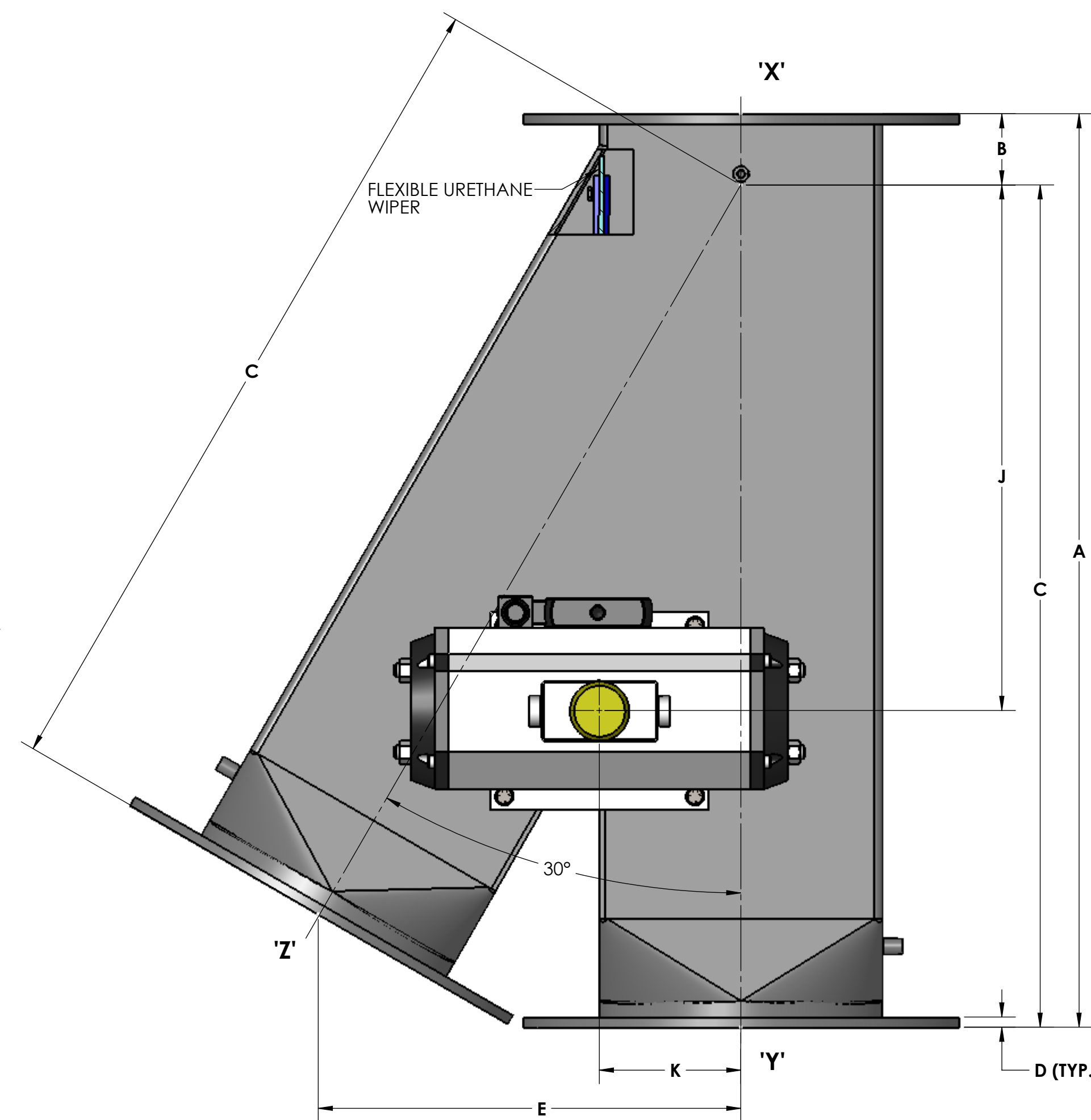
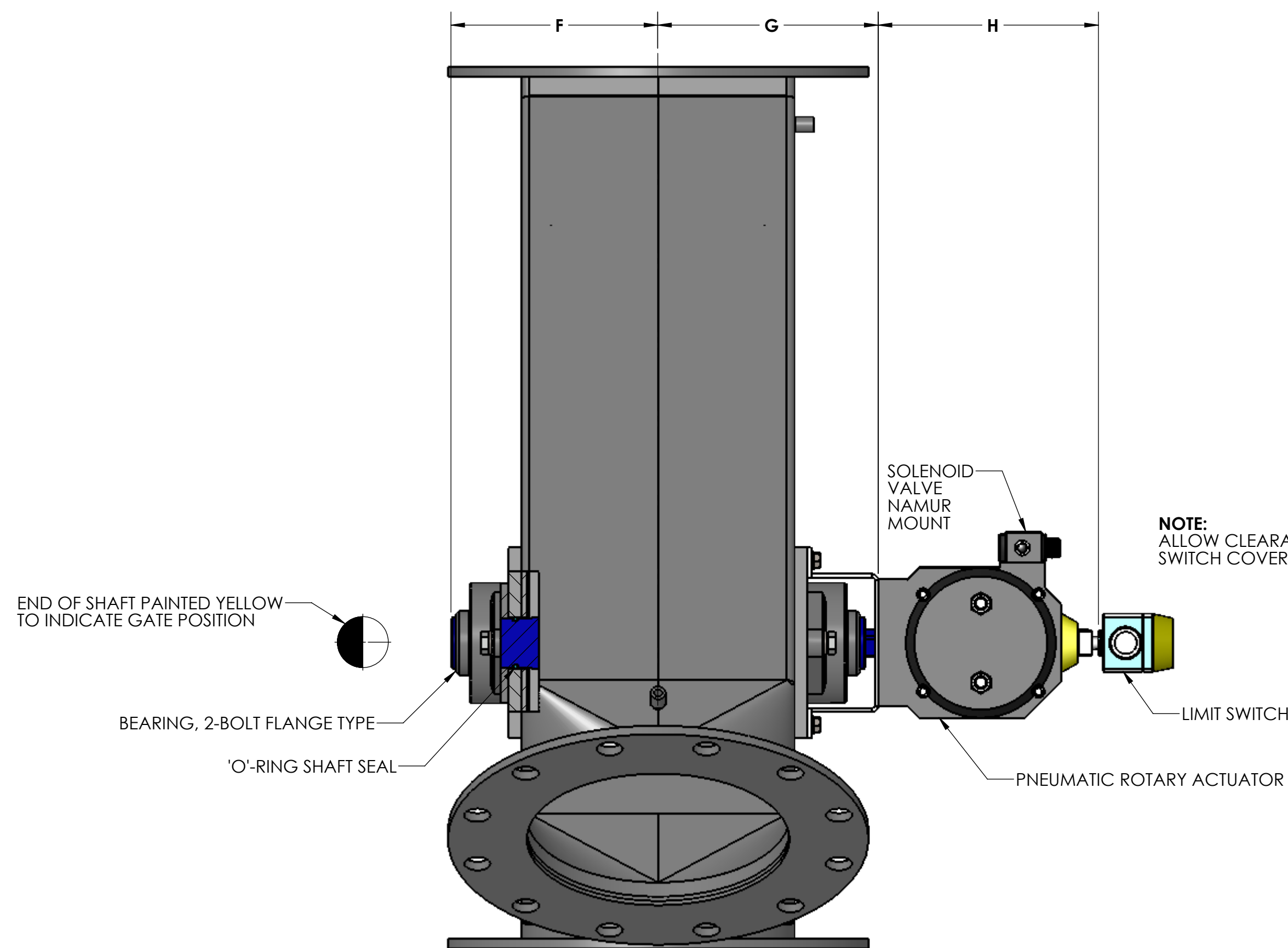

Size	A	B	C	D	E	F	G	H	J	K	L	M	N	P	Q	R	S	T	U	V
4	20.00	2.00	18.00	.25	9.00	4.44	4.50	5.59	7.84	2.12	9.00	7.50	4	.75	7.50	4.00	.62	3.12	-	8
5	22.25	2.50	19.75	.25	9.88	4.94	5.00	5.59	9.72	2.62	10.00	8.50	5	.88	8.50	5.00	.62	3.62	-	8
6	24.00	2.50	21.50	.25	10.75	5.44	5.50	5.59	11.59	3.12	11.00	9.50	6	.88	9.50	6.00	.62	4.12	-	8
8	28.50	2.12	26.38	.38	13.19	6.88	6.94	7.72	15.62	4.19	13.50	11.75	8	.88	11.50	8.00	.62	5.12	2.56	16
10	33.50	2.50	31.00	.38	15.50	7.88	7.94	7.72	19.38	5.19	16.00	14.25	10	1.00	14.75	10.00	1.00	6.38	6.38	16
12	39.50	2.50	37.00	.38	18.50	8.88	8.94	7.72	23.09	6.19	19.00	17.00	12	1.00	16.75	12.00	1.00	7.38	3.69	16

SPECIFICATIONS ARE SUBJECT TO CHANGE WITHOUT NOTIFICATION

NOTES:

- VALVES ARE OF FABRICATED CONSTRUCTION AND AVAILABLE IN STEEL, ALUMINUM OR STAINLESS STEEL.
- VALVES ARE AVAILABLE WITH ROUND OR SQUARE FLANGED ENDS, OR PLAIN ENDS.
- RIGHT HANDS ASSEMBLY IS SHOWN WITH SIDE BRANCH 'Z' ON LEFT SIDE AND ACTUATOR ON NEAR SIDE. LEFT HAND ASSEMBLY IS WITH SIDE BRANCH 'Z' ON RIGHT SIDE AND ACTUATOR ON NEAR SIDE. (RIGHT HAND ASSEMBLY IS STANDARD)

GENERAL TOLERANCES	
UNLESS OTHERWISE SPECIFIED THE FOLLOWING SHALL APPLY	
MACHINING - .XX= .02 .XXX= .005 ANGLE= .50°	
SURFACE ROUGHNESS HEIGHT 63 MICRONS OR LESS	
FABRICATION - UNDER 6 6 TO 24 24 TO 60 OVER 60	
± .06 ± .12 ± .19 ± .25	
UNLESS OTHERWISE SPECIFIED DIMENSIONS ARE IN INCHES	

REV. NO.	DESCRIPTION	DATE	BY
REVISIONS			
CUSTOMER			
CUST. NO.			
YOUNG ORDER NO.			
TITLE			
YOUNG INDUSTRIES MODEL 'TDV' BLADE DIVERTER VALVE, 30 DEGREE, W/ PNEUMATIC ACTUATOR, STANDARD DIMENSION SHEET			
THE YOUNG		INDUSTRIES, INC.	
MUNCY, PENNSYLVANIA		17756	
TELEPHONE:		570-546-3165	
DRAWN BY: BMF	DATE DRAWN: 4/14/16		
CHECKED BY:	SCALE: 1:4		
DRAWING NUMBER	S-4-6925	REV:	