

ROUND INLET & OUTLET FLANGE DETAIL
SIZES 4" THRU 8" ONLY
150# ANSI DRILLING

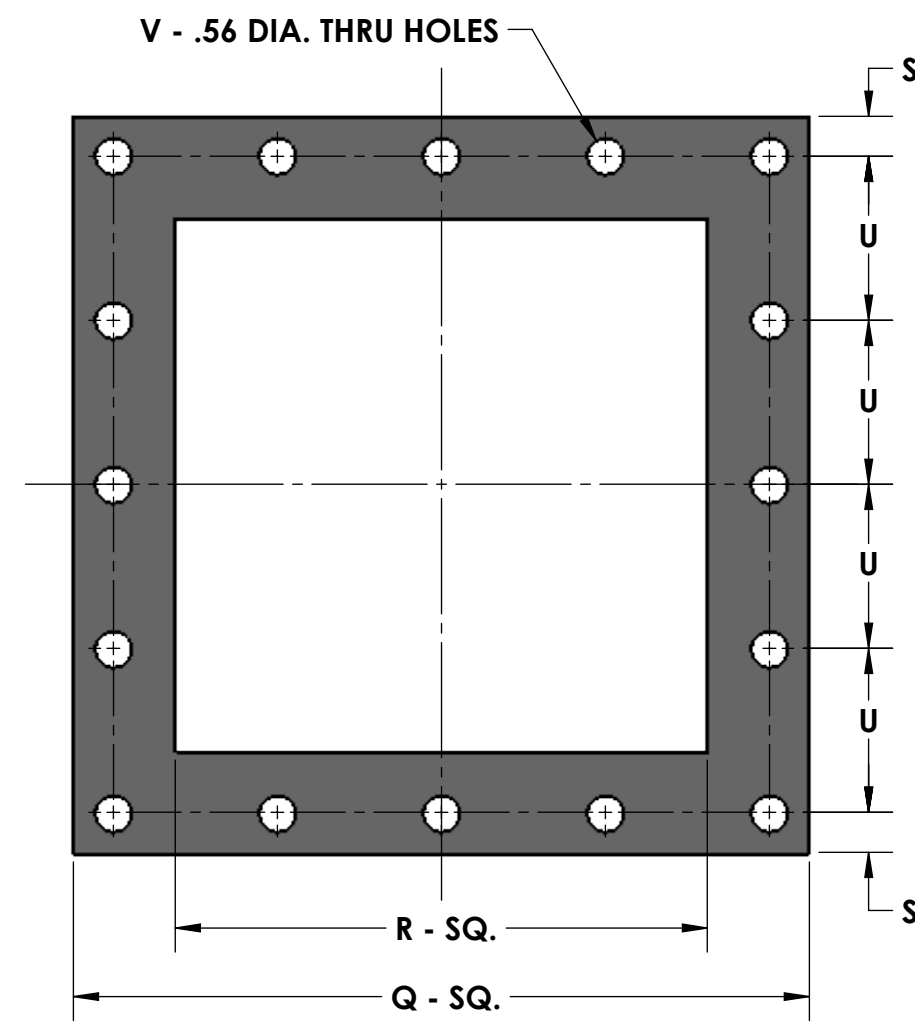

SQUARE INLET & OUTLET FLANGE DETAIL

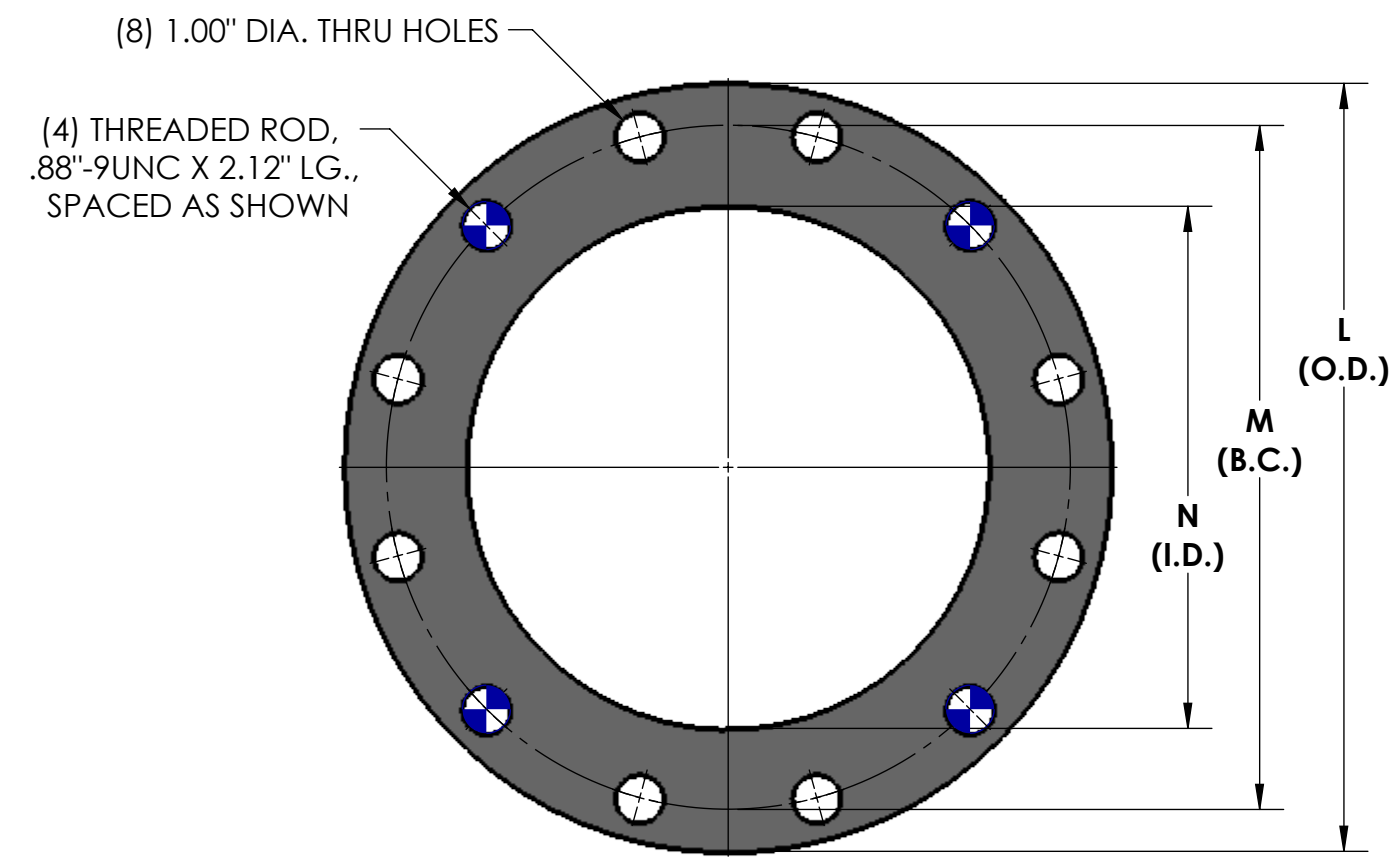

ROUND INLET FLANGE DETAIL
SIZES 10" & 12" ONLY
150# ANSI DRILLING

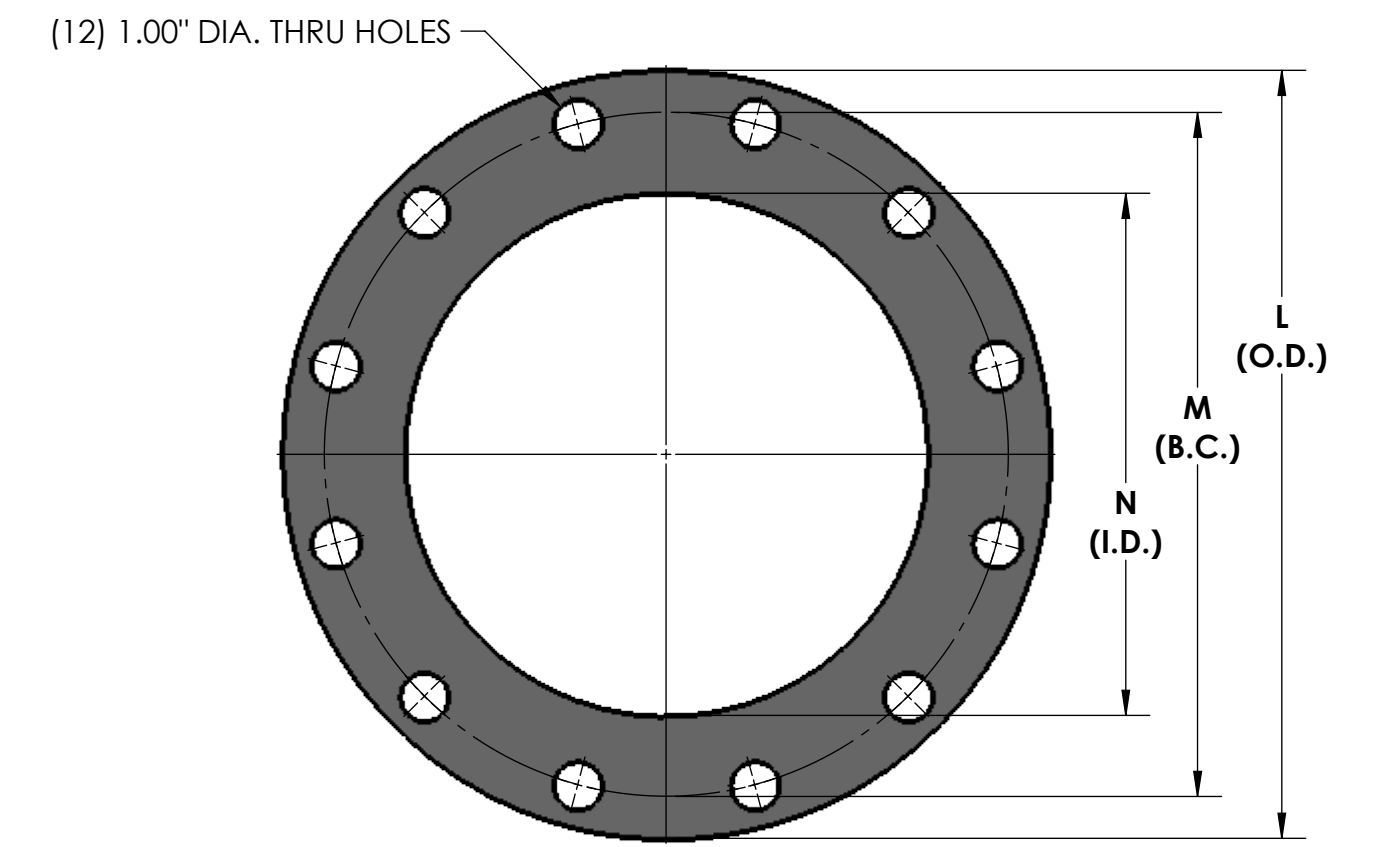

ROUND OUTLET FLANGE DETAIL
SIZES 10" & 12" ONLY
150# ANSI DRILLING

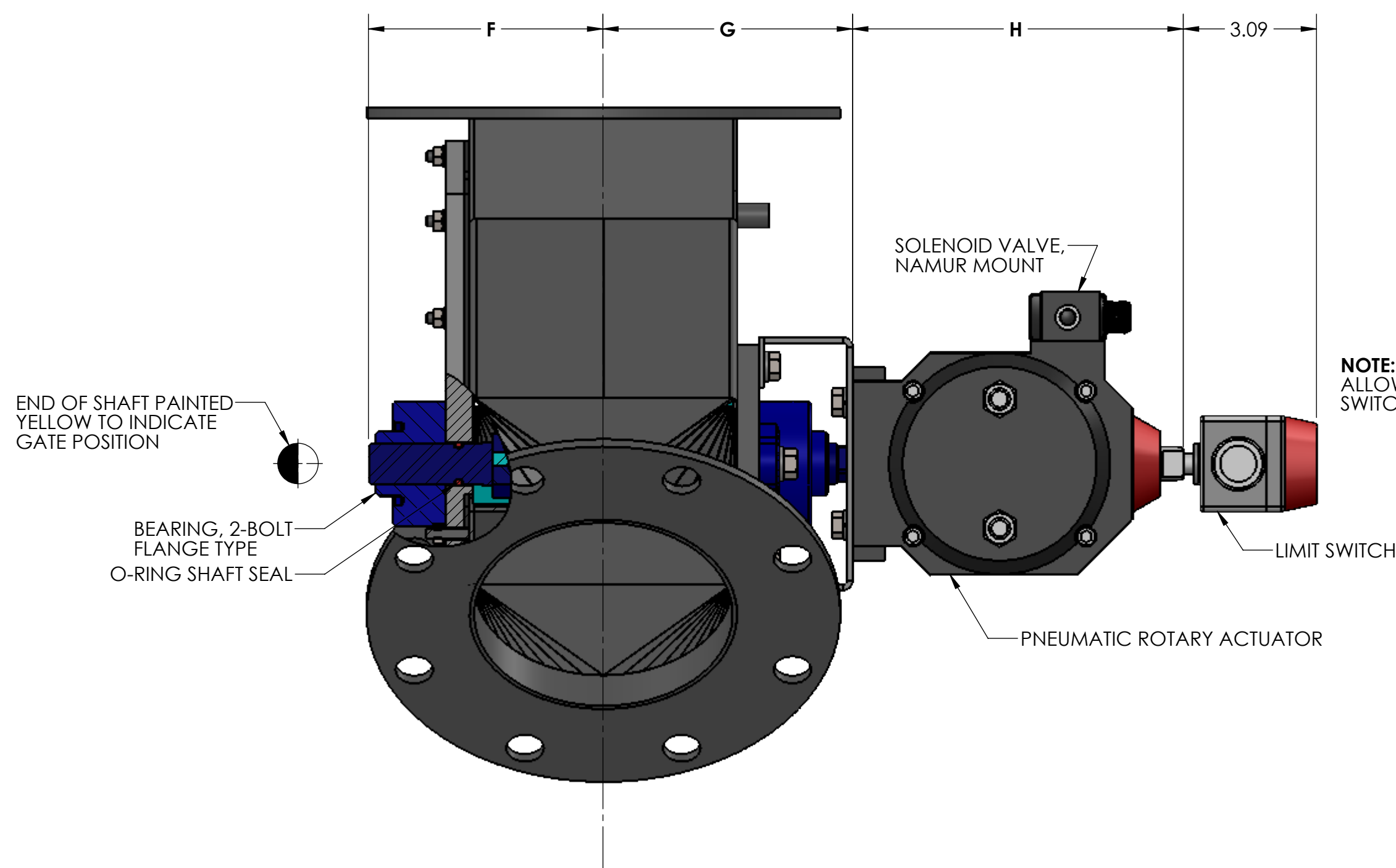

NOTE:
ALLOW CLEARANCE FOR
SWITCH COVER REMOVAL

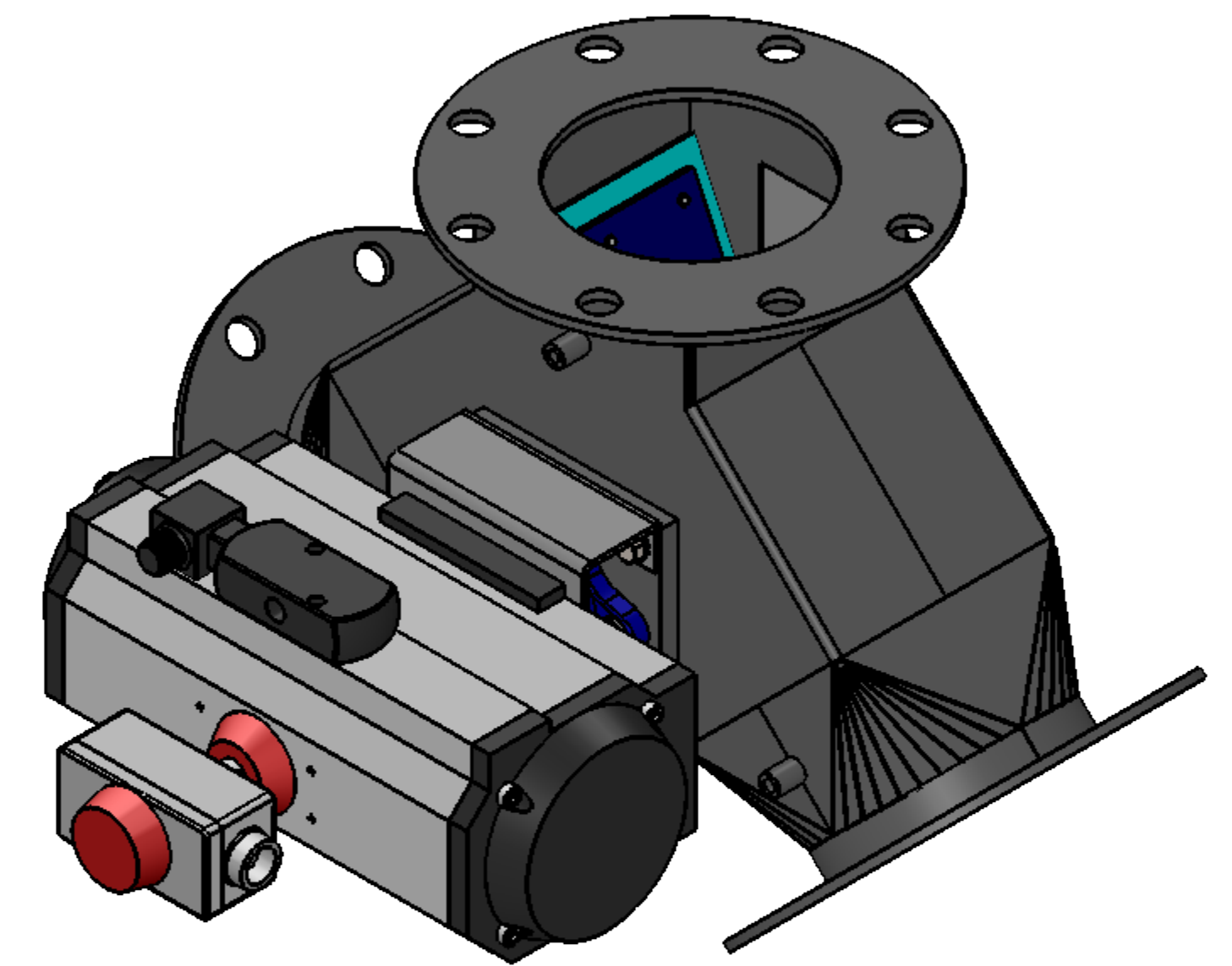
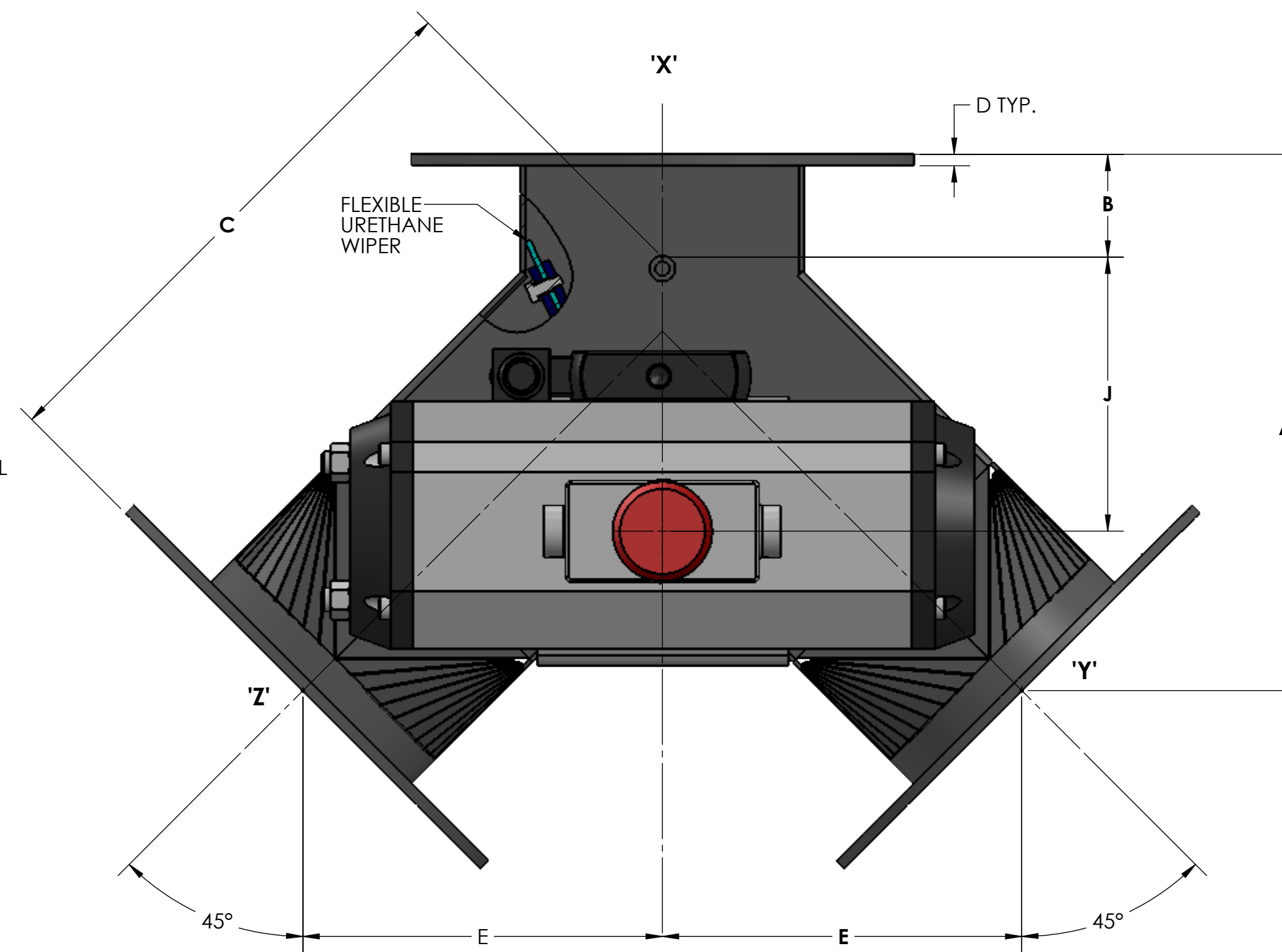

SIZE	A	B	C	D	E	F	G	H	J	L	M	N	P	Q	R	S	T	U	V
4	12.69	3.00	9.19	0.25	13.00	4.44	4.50	5.59	3.00	9.00	7.50	4.00	0.75	7.50	4.00	0.62	3.12	-	8.00
5	13.69	3.31	9.69	0.25	13.69	4.94	5.00	5.59	3.69	10.00	8.50	5.00	0.88	8.50	5.00	0.62	3.62	-	8.00
6	14.69	3.62	10.19	0.25	14.38	5.44	5.50	5.59	4.38	11.00	9.50	6.00	0.88	9.50	6.00	0.62	4.12	-	8.00
8	17.31	3.00	13.50	0.38	19.09	6.88	6.94	7.72	5.94	13.50	11.75	8.00	0.88	11.50	8.00	0.62	5.12	2.56	16.00
10	-	-	-	0.38	-	7.88	7.94	7.72	-	16.00	14.25	10.00	1.00	14.75	10.00	1.00	6.38	3.19	16.00
12	-	-	-	0.38	-	8.88	8.94	7.72	-	19.00	17.00	12.00	1.00	16.75	12.00	1.00	7.38	3.69	16.00

NOTES:

- VALVES ARE OF FABRICATED CONSTRUCTION AND ARE AVAILABLE IN STEEL, STAINLESS STEEL OR ALUMINUM.
- VALVES ARE AVAILABLE WITH ROUND OR SQUARE FLANGED ENDS OR PLAIN ENDS.
- RIGHT HAND ASSEMBLY IS SHOW WITH SIDE BRANCH 'Z' ON LEFT SIDE AND ACTUATOR ON NEAR SIDE. LEFT HAND ASSEMBLY IS WITH SIDE BRANCH 'Z' ON RIGHT SIDE AND ACTUATOR ON NEAR SIDE. (RIGHT HAND ASSEMBLY IS STANDARD)

GENERAL TOLERANCES	
UNLESS OTHERWISE SPECIFIED THE FOLLOWING SHALL APPLY	
MACHINING - .XX= .02 .XXX= .005 ANGLE= .50°	
SURFACE ROUGHNESS HEIGHT 63 MICRONS OR LESS	
FABRICATION - UNDER 6" 6 TO 24" 24 TO 60" OVER 60"	
± .06 ± .12 ± .19 ± .25	
UNLESS OTHERWISE SPECIFIED DIMENSIONS ARE IN INCHES	

REV. NO.	DESCRIPTION	DATE	BY
REVISIONS			
CUSTOMER: *			
CUSTOMER PO NUMBER: *			
YOUNG JOB NUMBER: *			
TITLE			
YOUNG INDUSTRIES, INC. MUNICIPALITY, PENNSYLVANIA 17756 TELEPHONE: 570-546-3165			
DRAWN BY: BMF		DATE DRAWN: 5/22/17	
CHECKED BY:		SCALE=1:3	
DRAWING NUMBER		SHEET	
S-4-7889		1 OF 1	
		REV:	